

# PWRcell® Battery Foot Bracket Kit

## Requirements for Mounting Foot and Wall Mount Brackets

The installation of this kit is required where battery installation is outdoors, or elevated greater than 1 3/4 in above a floor.

### Fastener Requirements

**NOTE:** The details below are minimum guidance. Consult local building codes and a licensed contractor to ensure the use of appropriate fasteners.

- Minimum 4 structural fasteners required for wall bracket, corrosion protected steel, diameter 1/4 in.
- Minimum 4 structural fasteners required for foot bracket. Use corrosion protected steel, diameter 1/4 in.
- Fastener head clearance 5/8 in tall, 7/8 in diameter.
- Use a flat washer between the fastener head and wall bracket if fastener is not a flanged head.
- All fasteners must be field supplied.
- Installer must ensure that fasteners selected are appropriately rated for this application.

### Fastening Requirements

- All fasteners must engage 1 1/2 in (3.8 cm) with a structural member.
- If mounting into stud framing use a stud finder to locate the center of the stud.
- If mounting into stud framing, the bracket must be fastened to a minimum of two separate structural members.
- If mounting to a foundation or masonry, make sure fasteners are clear of any mortar joints.
- If stud is greater than 16 in on center, a cross brace must be used.
- If mounting on vinyl siding, unistruts must be used.
- Brackets must be level.
- Each horizontal brace requires a minimum of two fasteners.

## Installing Foot Bracket

**NOTE:** A template is included on the inside of the PWRcell Battery packaging and will help locate the holes for both wall and foot brackets.

Mount foot bracket to wall with the following procedure:

1. See **Figure 1**. Install the foot bracket bottom edge to a minimum height of 3 in and a maximum height of 6 in to keep the Battery Disconnect Switch at a maximum height of 79 in above grade.
  - a. If greater height is desired, installation of an additional DC disconnect listed 30 A 600 V will be required for the battery to meet NEC 404.8(A).

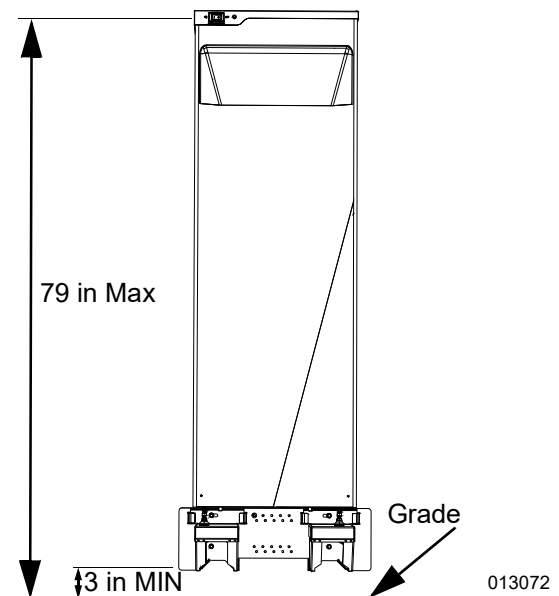

**Figure 1. Foot Bracket Install Height**

2. See **Figure 2**. Locate structural members to mount foot bracket (A). If structural members are greater than 16 in apart, install cross brace to ensure mounting to a solid structure.
3. See **Figure 2**. Install foot bracket (A) using lower holes with fasteners and washers (B) making sure bracket remains plumb and level.

**NOTE:** Do not install the top fasteners at this stage. This will inhibit installation of the stands.

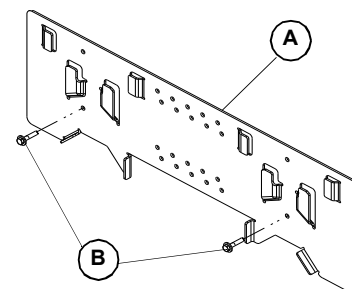

**Figure 2. Install Foot Bracket**

011153

- See **Figure 3**. Slide foot stands (C) onto foot bracket (A) making sure underside of pockets clear bottom bracket before engagement. Proper installation is achieved by lining up the top edge of foot bracket to the bottom edge of the stands.

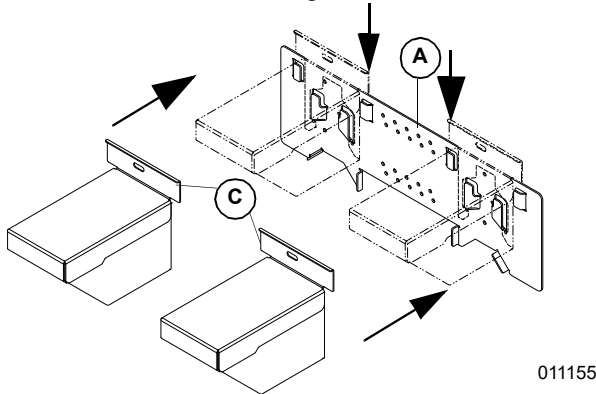

**Figure 3. Insert Stands Onto Foot Bracket**

- See **Figure 4**. Use flat washers and fasteners (D) to secure top of foot bracket and stands.

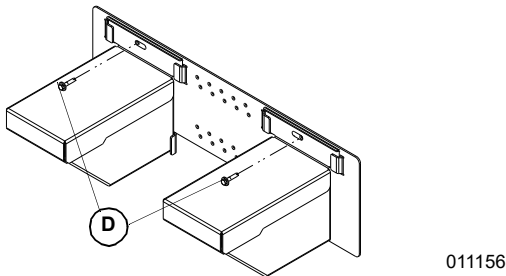
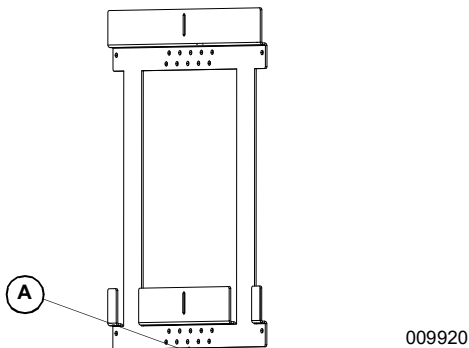

**Figure 4. Install Top Fasteners Through Stands and Foot Bracket**

## Installing Wall Bracket

**NOTE:** Included with PWRcell Battery.

- See **Figure 5**. Bottom edge (A) is 29-5/8 in (752 mm) off the floor for installations that are not elevated. See the following procedure for elevated installation.



**Figure 5. Wall Bracket**

Mount Wall Bracket to wall with the following procedure:

- See **Figure 6**. Project a vertical line up from the top mounting fastener in the foot bracket (B).
- Place a mark on the projected line 30 11/16 in (779.2 mm) above the top mounting fastener of the foot bracket (B).
- Insert first fastener in the lower hole of the wall bracket (A) at the mark placed in step 2, leaving it partially loose until bracket is in alignment and plumb.
- Level wall bracket (A) and double check alignment. Double check measurement of 30 11/16 in (779.2 mm) is the same for the other lower mounting fastener in wall bracket (A). Make sure opposite wall bracket (A) fastener is in alignment for 16 in on center studs.
- Install and tighten both lower wall bracket mounts.
- Double check wall bracket (A) fasteners are in alignment with foot bracket (B) fasteners and wall bracket (A) is still plumb.
- Install a minimum of two fasteners in the top holes of the wall bracket (A).

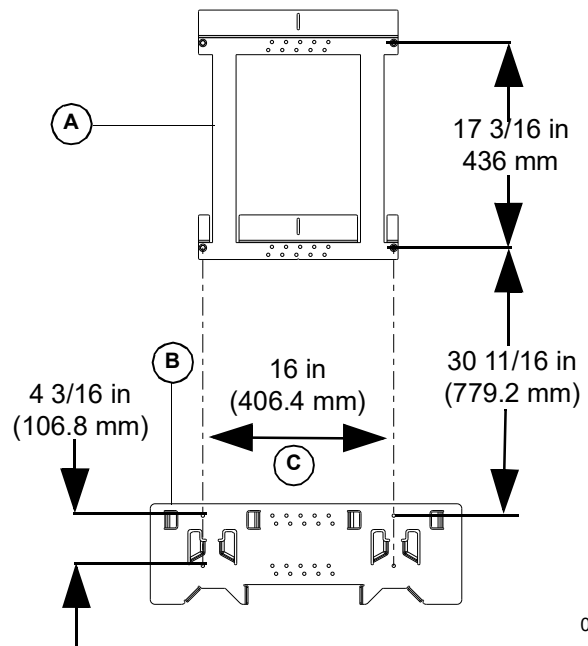

**Figure 6. Foot Bracket and Wall Bracket Alignment**

Part No. A0001699662 Rev A 9/8/2021

©2021 Generac Power Systems, Inc.

All rights reserved.

Specifications are subject to change without notice.

No reproduction allowed in any form without prior written consent from Generac Power Systems, Inc.

**GENERAC**

Generac Power Systems, Inc.  
S45 W29290 Hwy. 59  
Waukesha, WI 53189  
1-888-GENERAC (1-888-436-3722)  
[www.generac.com](http://www.generac.com)