

INSTALLATION MANUAL

RT-MINI

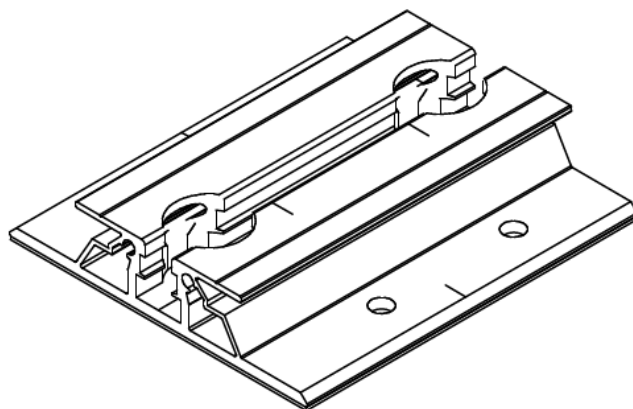

Contents

- INTRODUCTION1
- PERIODICAL INSPECTION2
- Tools Required for Assembly2
- INSTALLATION SAFETY3
- PART A: Materials4
- PART B: Bracket Installation5
- ADDENDUM: Metal Roof Installation17
- ADDENDUM: Classic rib Metal Roof Installation.....22
- ADDENDUM: MINI used with L-Foot and Rail28



10620 Trenea St, Suite 230
 San Diego, California 92131
 TEL (858) 935-6064

INSTALLATION MANUAL

Contents

• Introduction	-----1
• Periodical Inspection	-----2
• Tools Required for Assembly	-----2
• Installation Safety	-----3
PART A: Materials	-----4
PART B: Bracket Installation	-----5
1. Installation of Brackets	-----5
(1) Bolt Options	-----5
(2) Bracket Layout	-----5
(3) Bracket Installation	-----8
ADDENDUM: Installation Instruction for Metal Roofing	
1. Requirements	-----17
2. Marking	-----18
3. Bracket Installation	-----19
ADDENDUM: Installation Instruction for Classic rib Metal Roofing	
1. Requirements	-----22
2. Marking	-----23
3. Bracket Installation	-----24
ADDENDUM: MINI used with L-Foot and Rail	-----28

Introduction

Please review this manual thoroughly before installing your Roof-Tech system. Aside from reading this manual, please review the P.E. Stamped Engineering Letters for the RT-MINI products for your State. This manual provides supporting documentation for the installation of RT-MINI products.

We recommend installer to carefully review the instructions provided by the other manufacturers of the products being installed with the RT-Mini and become acquainted with OSHA's safety procedures prior to installing the PV system.

The installer is solely responsible for:

- Handling and installing the PV modules and rail system according to the manufacturer's instruction, with special attention for the suggested clamping locations on the frame.
- Complying with all applicable local or national building codes, standards and industry best practices including any code that may supersede this manual.
- Ensuring that Roof-Tech's and other products are appropriate for the particular installation and the installation location.
- Ensuring that the roof, its rafters, connections, and other structural support members can support the array under all code level loading conditions.
- Using only Roof-Tech parts and installer-supplied parts as specified by Roof-Tech. (Substitution of parts may void the warranty and invalidate the letters of certification.)
- Verifying the strength of any alternate mounting devices used in lieu of the anchoring screws.
- Maintaining the waterproof integrity of the roof.



Attention

To maintain the flashing performance, avoid installation when the temperature is below 22F or above 176F. RT Butyl must be installed on a dry surface.

- Ensuring safe installation of all electrical and mechanical aspects of the PV array.
- PE Stamped letters for the rail option are available at <https://roof-tech.us/support/>
- Ensuring correct and appropriate design parameters are used in determining the design loading used for design of the specific installation. Parameters, such as snow loading, wind speed, exposure and topographic factor should be confirmed with the local building official or a licensed professional engineer.

- Roof Tech recommends a thermal splice every 14 Ft., however, it must be determined by the installer based on the rail system installation instructions. The installer must also determine the maximum allowed span and cantilever design parameters recommended by the rail system manufacturer. The RT-MINI can be installed on low slope roofs (Metal, EPDM, TPO, SBS Modified Bitumen/Torch-on, Asphalt) and steep slope roofs (Asphalt shingles, Metal). For low slope roofs, make sure there is positive drainage.

Periodical Inspection

Roof Tech Inc. recommends inspecting installed racking system periodically for loose components, loose fasteners and any corrosion. If found, those components are to be re-tightened, or replaced immediately. When a PV module needs to be removed from the PV array for maintenance and/or replacement, the electric bonding system may need to be temporarily restored to maintain the electrical bonding path. Please make sure the system electrical circuits and disconnects are in the open position and the entire system is powered down. Cover the fronts of modules in the array with an opaque material to stop the production of electricity. Use appropriate safety equipment such as insulated tools and insulating gloves to protect yourself.

Maintenance of the PV modules should be carried out by licensed contractors, according to the PV manufacturer's installation/maintenance instructions and Roof Tech's installation instructions.

Maintenance should not be conducted under a wet and/or high wind conditions.

Tools Required for Assembly

Tools needed for installing the RT-MINI

- Hex bit socket (8 mm)
- Drill and ϕ 3 mm Drill Bit for sheet metal (for Installation on Metal Roof)
- Measuring tape
- Chalk line

※L-Foot mounting option

Item	Torque
W5/16 or M8 Bolt	15.8 N·m (140)

Technical Note

Proper torque values for a wood screw will vary depending on the rafter and/or deck characteristics; hardness, age, and moisture of the wood. Tighten the M5x60mm wood screws until the conical washer stop rotating.

Stainless hardware is soft and if dry torqued too quickly it may cause the nut and bolt to seize.

Roof Tech recommends all stainless steel threads be lubricated. This will make it easier to tighten nuts to bolts, avoid galling, and facilitate adjustments before the nut is properly torqued. Therefore, avoid the use of an impact driver.

Moisture Content

RT Butyl Flexible Flashing is to be installed on dry mounting surfaces.

Determining how wet is too wet:

First, remove the paper backing from an RT product exposing the clean RT Butyl.

Second, press the base, RT Butyl side down against the surface.

Third, pick up the base. If the base adheres to the roof, the roof is suitably dry for installation.

For Metal, EPDM and TPO remove water from the installation area with a cloth or squeegee before placing and affixing the base. A heat gun, Sodium Chloride or alcohol is suitable to remove ice from the roof surface.

Installation Safety

The installation process requires working on sloped and elevated building surfaces, in outdoor weather conditions, using tools and heavy components designed for the generation of electricity.

- Use properly anchored fall protection equipment.
- Use caution to prevent objects from falling or dropping off the roof area.
- Cordon off ground areas directly beneath the roof work area when possible.
- Always use personal protection equipment such as safety glasses, gloves, etc.
- Do not perform installation in excessively wet, windy, or inclement weather conditions.
- When working in hot weather, work crews should take care to prevent symptoms of over-heating or dehydration.
- Use proper lifting and carrying techniques when handling heavy components at the job site. If conditions are challenging for moving PV modules to the roof area, use a mechanical lift.
- Follow best practices when working around high-voltage electrical equipment.
- Do not anchor fall protection equipment to roof mounts, or any other inappropriate roof structure.

PART A: Materials

1. Items with RT-MINI

① RT-MINI Bracket Set

	Item
1A	RT-MINI
1B	Screw 5.0×60
1C	RT Butyl Flashing

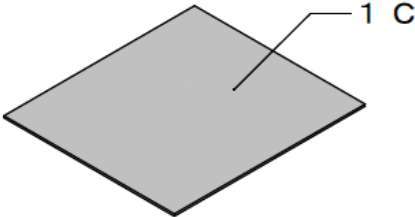
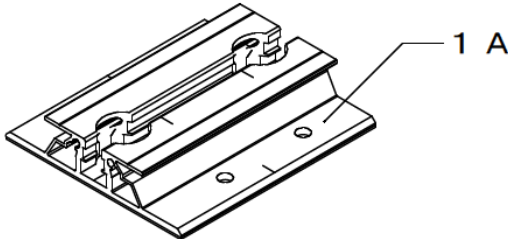
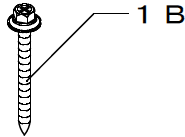

② Roof sealant

	Item
2A	Roof sealant

- ※Recommended Product
- Henry : 208R, 209, 925 (Black)
 - Geocel:S2, S4 (Black)
 - Sashco : Through the Roof
 - Boss : 125 (Black)
 - Top Industrial: Rain Buster 850, 900
 - Chem Link: M1
 - NPC Solar Seal 900
 - GE All Purpose 100% Silicone

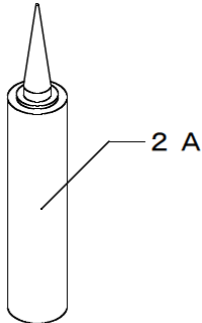

Note: Above sealants evaluated for asphalt roofs!

PART B: Bracket Installation

1. Installation of Brackets

(1) Bolt options

- a) For the 5/16" or M8 hex bolt, use the lower channel. (**L-Foot mounting option**)

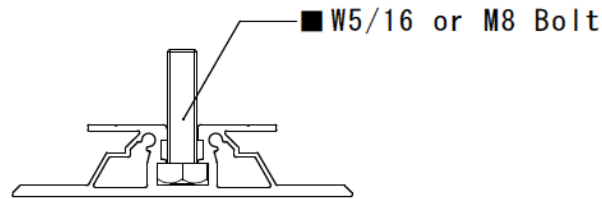

- b) For the 1/4" hex bolt, use upper channel. (**EMT clamp mounting option**)

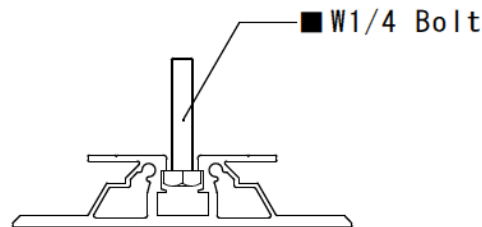

Note: M6 hex bolt will not fit the RT-MINI base.

(2) Brackets Layout

There is 1 9/16 inch (40mm) adjustability to secure the bolt.

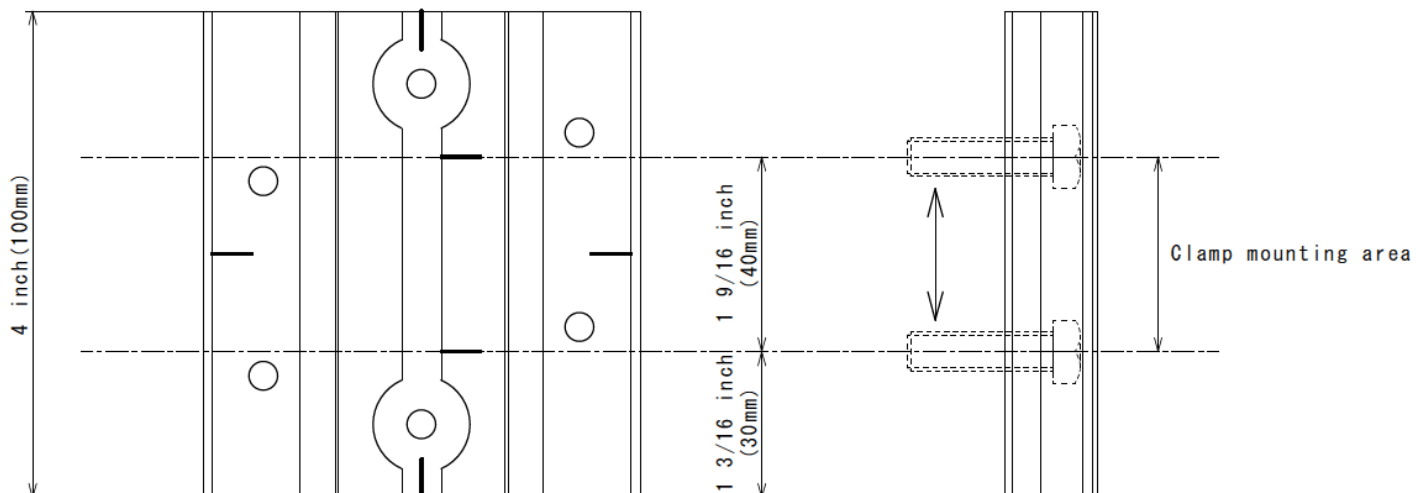

① Locate and place MINI base on the cross section of chalk line.

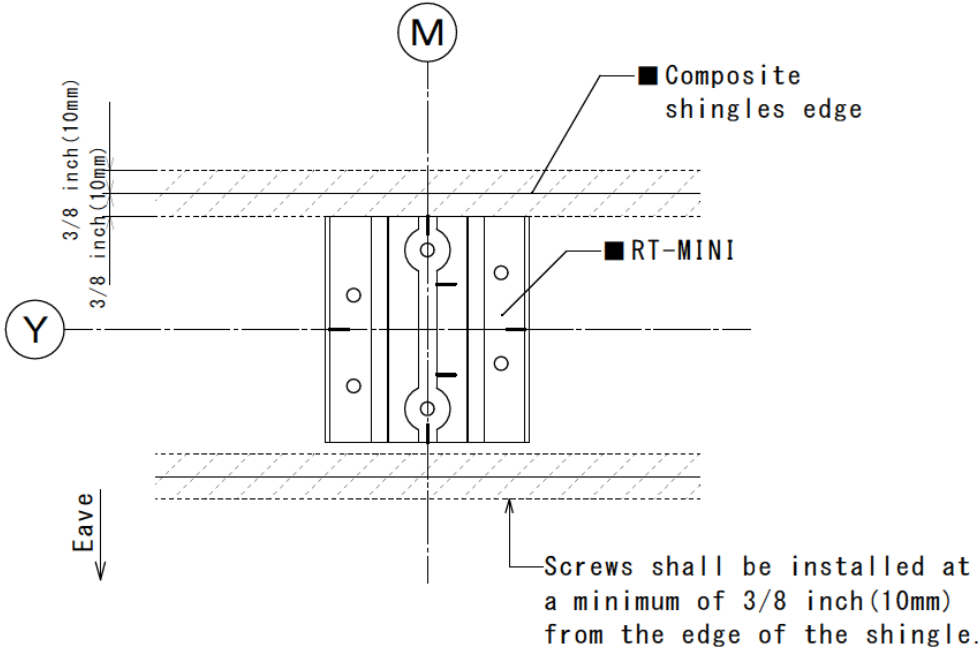

② Protecting the edge of the shingles.

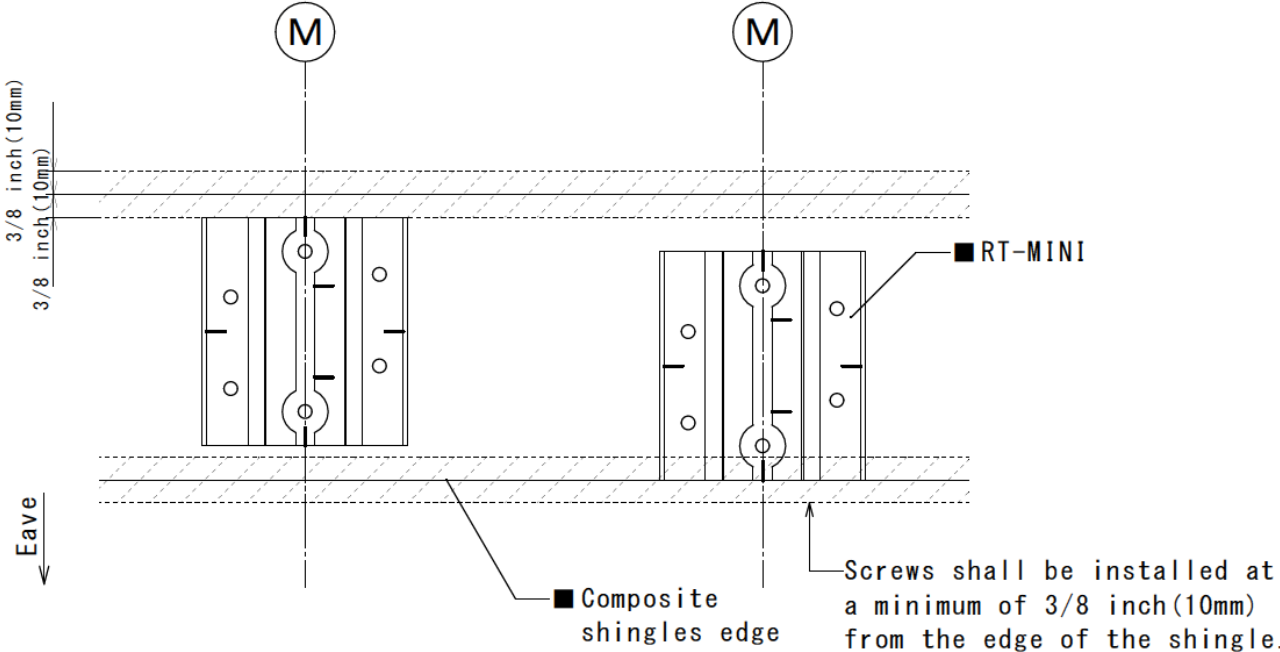

Note: The MINI base is structurally engineered to be mounted on the above position (structural). However if used for accessories such as junction boxes or EMT with no structural value, It can then be mounted on any orientation.

- ③ Chalk line according to the layout plans to indicate bracket's position.
- ④ Aligning the brackets. Choose the most suitable rafter, then mark the center.
 - (i) Line M: Vertical Bracket center line.
 - (ii) Line Y: Horizontal Bracket center line.

The Engineer of Record (EOR) shall verify the framing capacity and fastener installation for building code compliance including those of the National Design Specification for Wood Construction (NDS 2005/2012/2015) as applicable.

Attention

According to the NDS, the distance from the side edge of the rafter and the 5 mm diameter mounting screws for RT-MINI shall be at least 5/16 inch (7.9 mm) from the edge.

Note: Minimum Edge Distance = 1.5D
Where D is the Diameter of the screw.
Direction of Loading: Parallel to Grain
(See NDS 2015 Table 12.5.1c.)

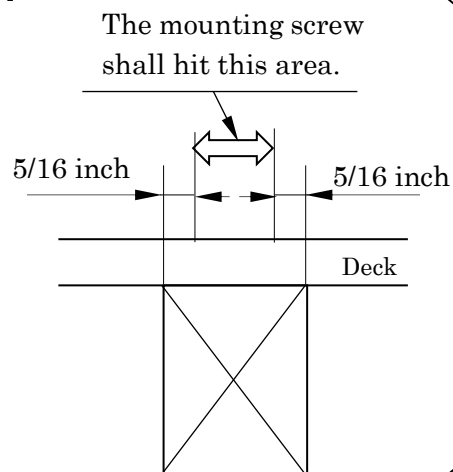

(3) Bracket Installation

! Attention

To maintain the flashing performance, avoid installation when the temperature is below 22F or above 176F. RT Butyl must be installed on a dry surface.

- ① Mark the location at the intersection of the Y Line and M Line.

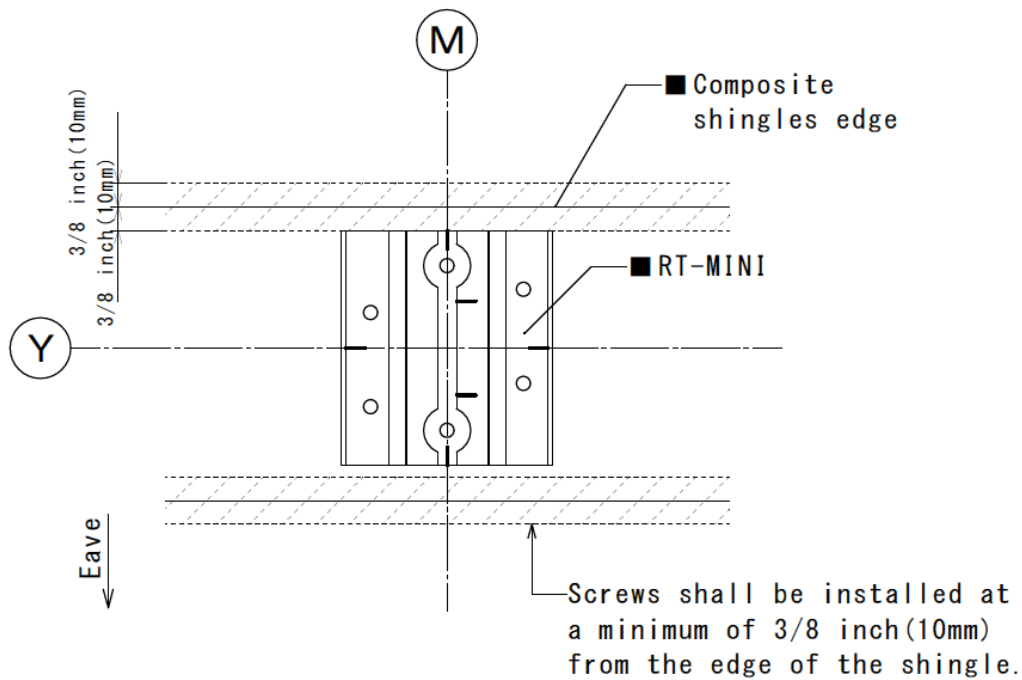

! Attention

Minimum clearance between mounting screws and the edge of the roofing shingle shall be 3/8 inch (10 mm).

In case the stainless screw hit the nail underneath the shingle;

- 1) Tip the driver at an angle.
- 2) Use a 3 mm steel drill to make a hole.
- 3) If possible, remove the nail from underneath.

② Adjust the RT butyl tape to match the height of the upper shingle. When there is a gap, a slit, or a height difference at the mounting location of the bracket, use additional RT butyl tape.

● When there is a slit at the installation spot, fill in with the additional RT butyl tape. The slit must be filled with RT butyl tape.

● When there is a slit above the bracket, fill it in with RT butyl tape to match its shape. Apply roof sealant around the RT butyl tape.

Notice that the roof sealant is only used to add a protective layer to the RT butyl tape.

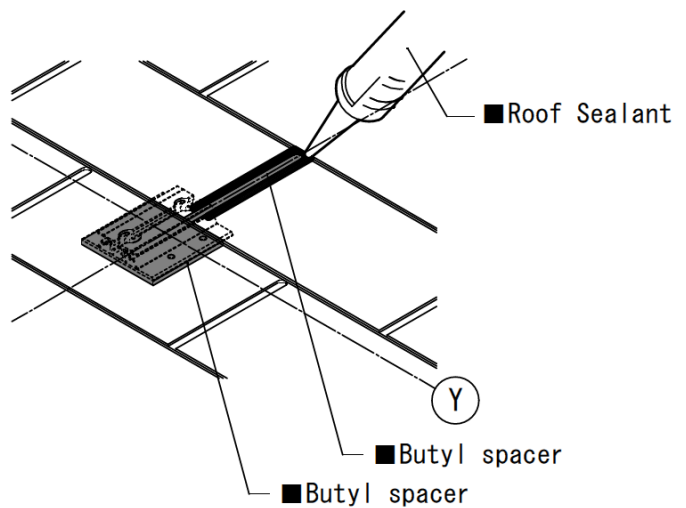
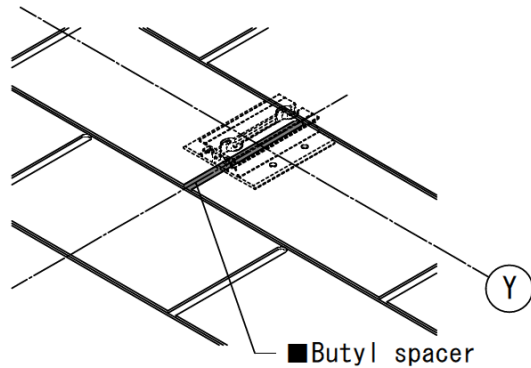

Rafter or Deck Install

③ If there is a shingle gap within 2 inches from the base, sealant shall be applied to the gap as it is shown.

● Best to position the bracket 2 inches away from the slit.

● If the mounting screw is within less than 2 inches from the slit, fill the slit with roof sealant.

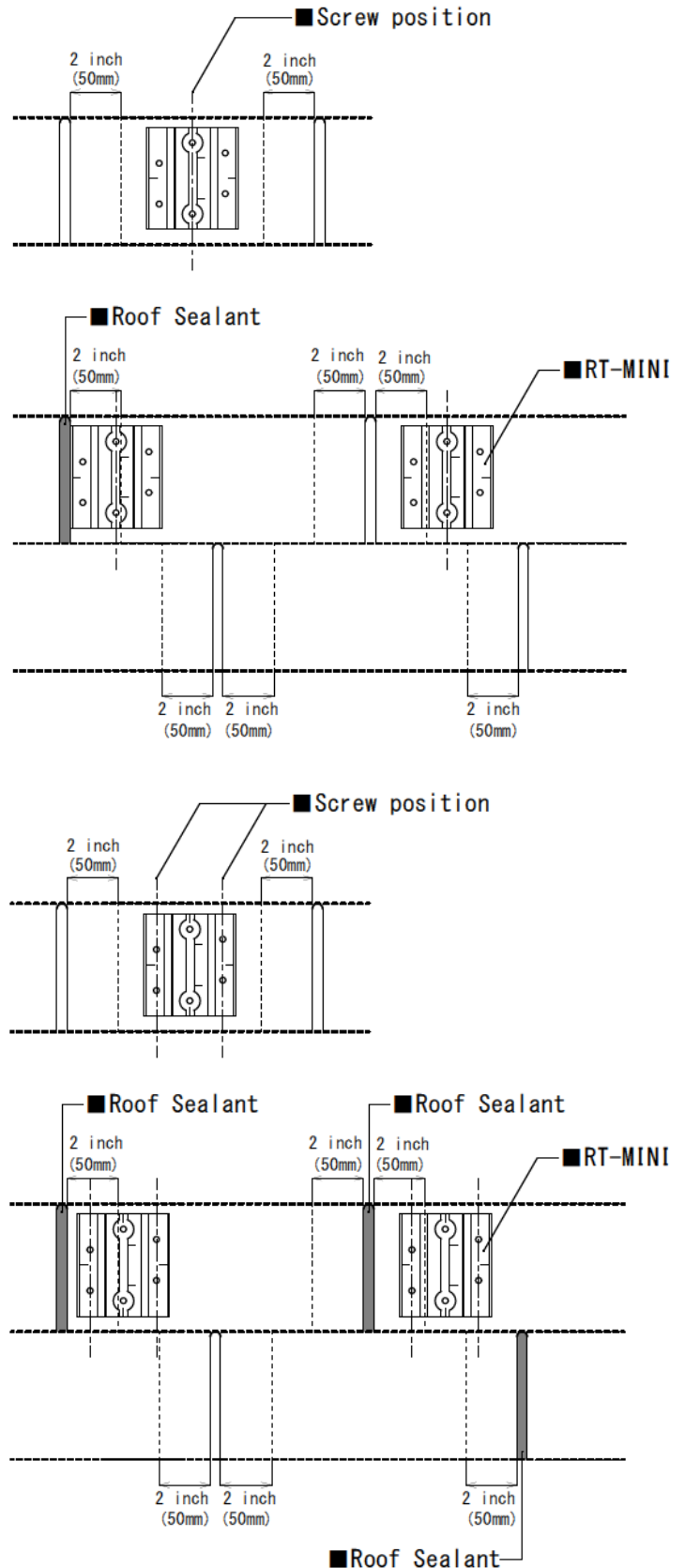

[Case 1]

- Use RT butyl tape to level the surface of the composite shingle roof.

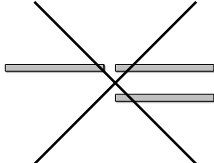
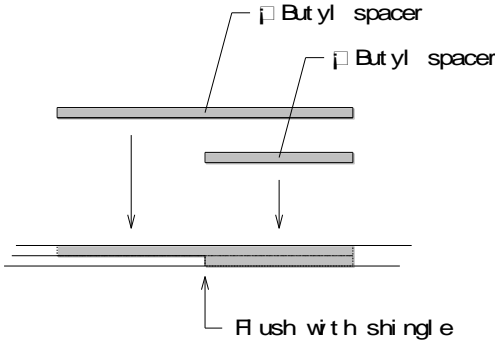

Note: Do not splice the butyl tape.

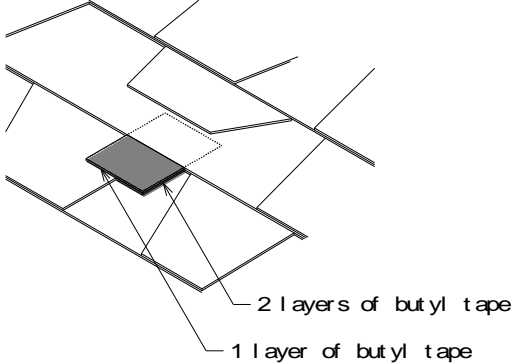
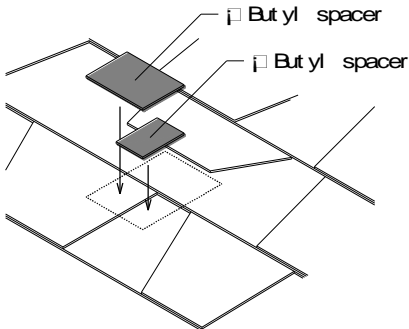
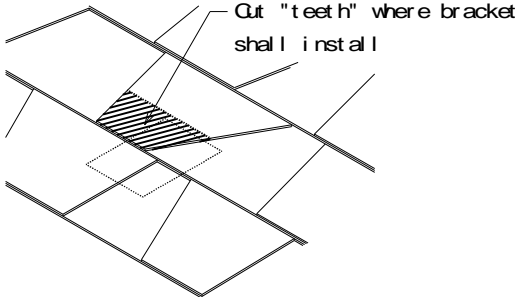

[Case 2]

- Building layers of RT butyl for the bracket to be mounted over the teeth region of composite shingle roofs.

We recommend 4 layers maximum.

Layer 1 is already applied to the bottom of the bracket.

The following layers must be cut to shape to cover the surface of the bracket at each location, assuring a leveled surface.

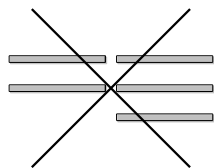
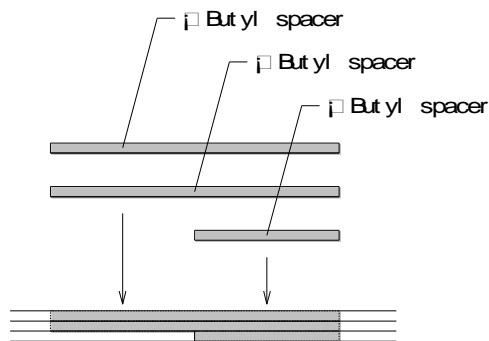
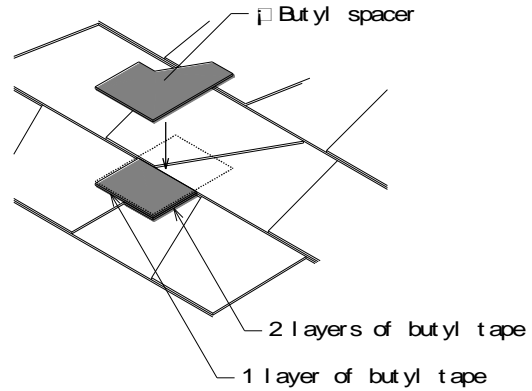
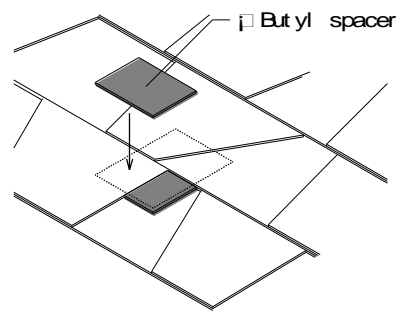
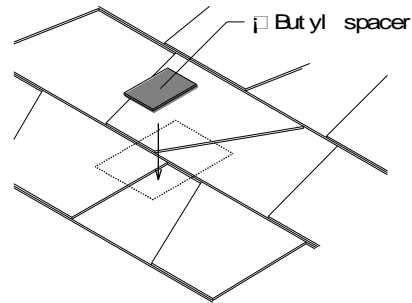

Note: Do not splice the butyl tape.

[Case 3]

● Roofing Leveling Option

The application of one layer of asphalt roofing shim with the proper asphalt roofing cement is an alternative to leveling when a Roof Tech base is to be installed between 2 levels (layers of asphalt shingles). The Roof Tech Structural Stamped letters are prepared based on 2 layers of shingles.

- ④ Peel off the protective paper from the RT butyl tape.

! Attention

Do not leave any protective paper on the surface of the RT butyl tape, it can cause an improper seal and may allow water intrusion under the bracket.

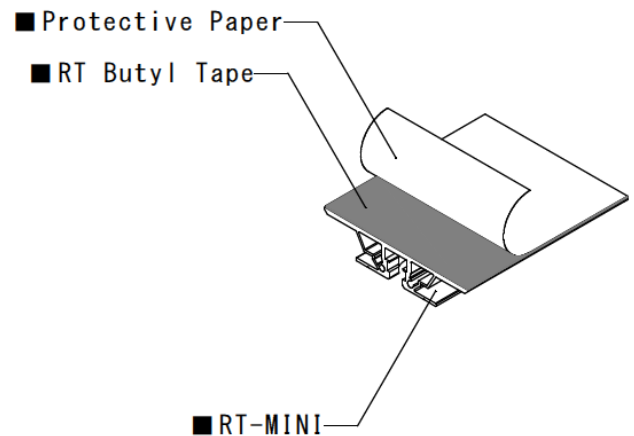

- When there are gaps in the position to install, fill them in with the additional RT butyl tape.

Note: Each bracket comes with RT butyl tape installed.

! Attention

Peel off the protection paper from both sides of any additional RT butyl tape.

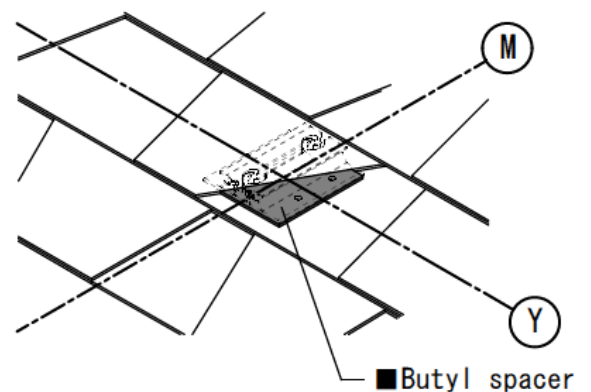

- ⑤ Installing the bracket.
- Place the brackets at the specified position and make sure the RT butyl makes good contact with the roofing surface.
- Slide the M8 or 5/16" Hex bolt into place before fastening the bracket on the roof.**
- Set the bracket with 2 ea. Screws, M 5.0 × 60 mm stainless wood screw using 8 mm hex socket.
- After completing process, make sure the brackets are securely fixed.

! Attention

The 5/16" or M8 Hex bolt must be set on the lower channel before both wood screws are fixed to the rafter.

[Fastening it to the Rafter]

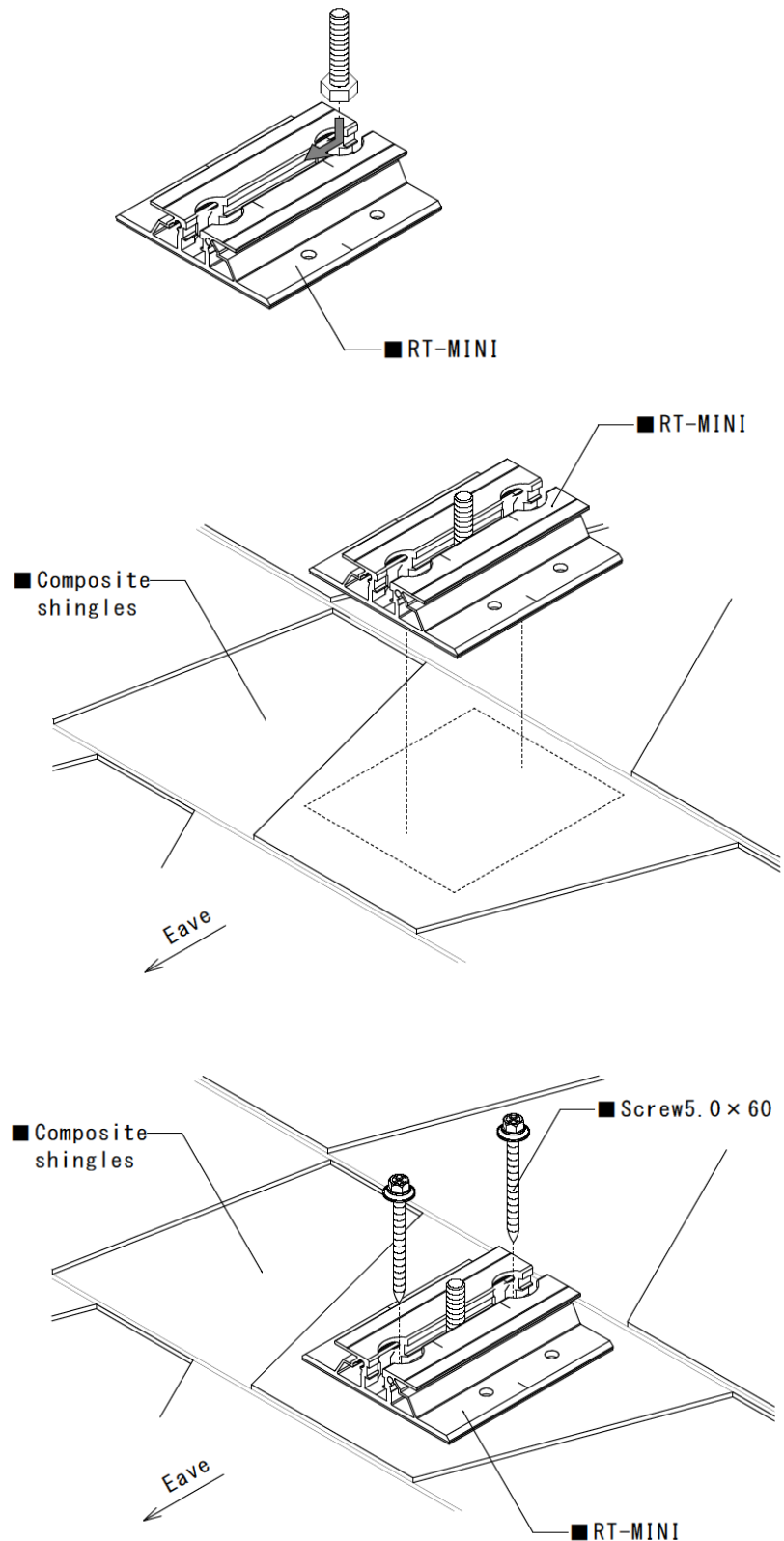

[Fastening it to the Roof Deck]

! Attention

When the MINI base is installed on the deck, 5 screws must be used. Four screws are fixed into the sides and 1 on the ridge side.

Note; Each MINI is shipped with 2 mounting screws. The installer must purchase additional screws when mounting it to the roof deck.

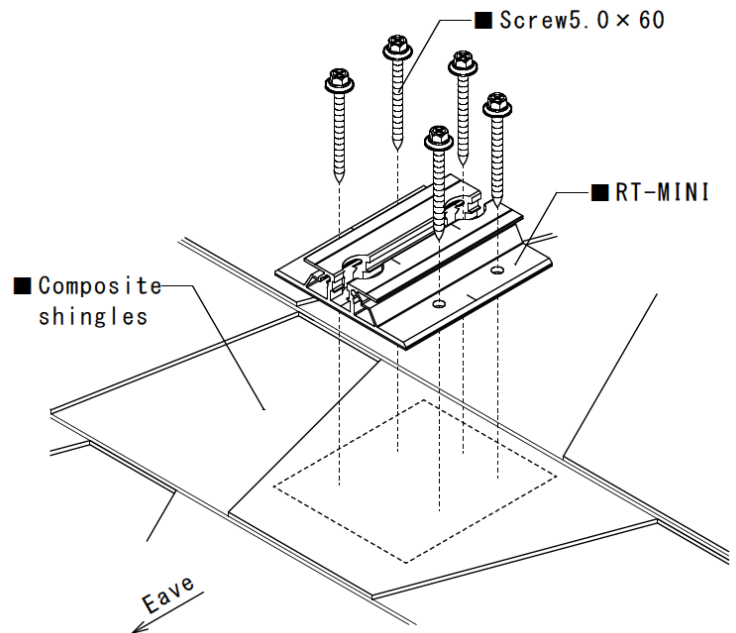

! Attention

Note: Proper torque values for the 5.0x60 mm screw will vary depending on the rafter and/or deck characteristics; hardness, age, and moisture of the wood. It should be tightened until the conical washer stops rotating.

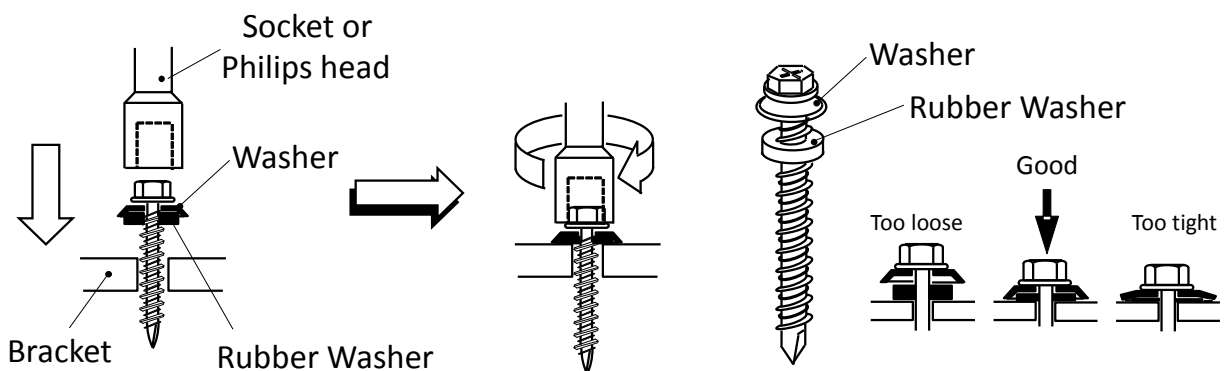

When tightening the screws please tighten all screws equally and avoid using an impact driver as it can over torque the screws or even snap off the head.

- ⑥ Apply roof sealant to the top and each side edge of the brackets. This adds additional UV protection. Cover the exposed RT butyl tape with roof sealant. No need to apply it to the bottom of the brackets.

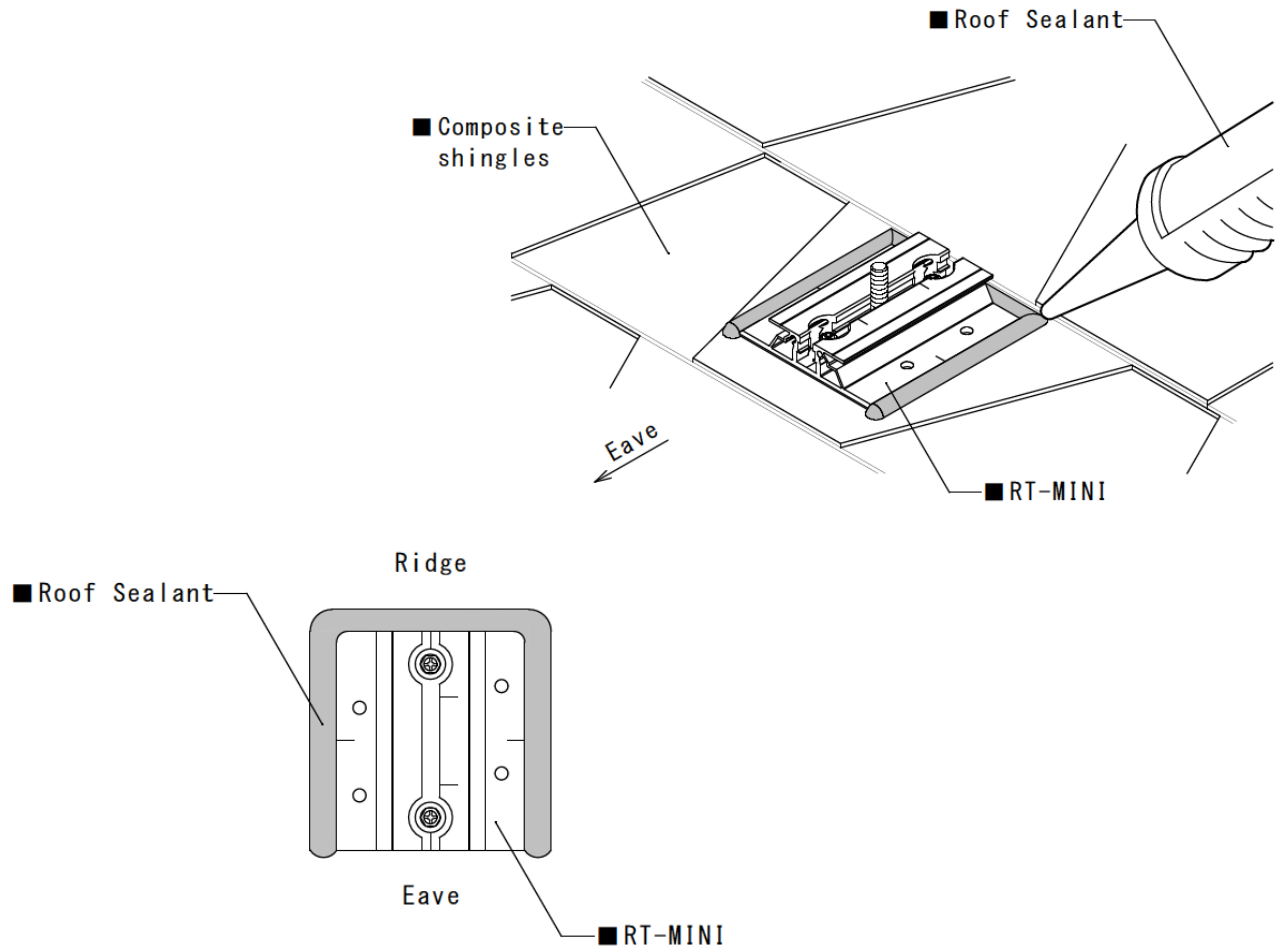

! Attention

You may verify that the screws underneath the deck panel are stained with butyl rubber. This indicates a good flashing performance.

Installation on a Metal Roofing

1. Requirement

- Applicable to maximum 20 gage metal decking.
- The roof should have sheathing (deck) board and the metal roofing should be flat and flush against the sheathing board at least 4 1/4 inch (108mm) by 4 3/4 inch (120mm) area at the bracket mounting location. The Roof Tech P.E. Letters are created for a minimum 7/16" OSB with 2x4" rafters 24 in o.c.

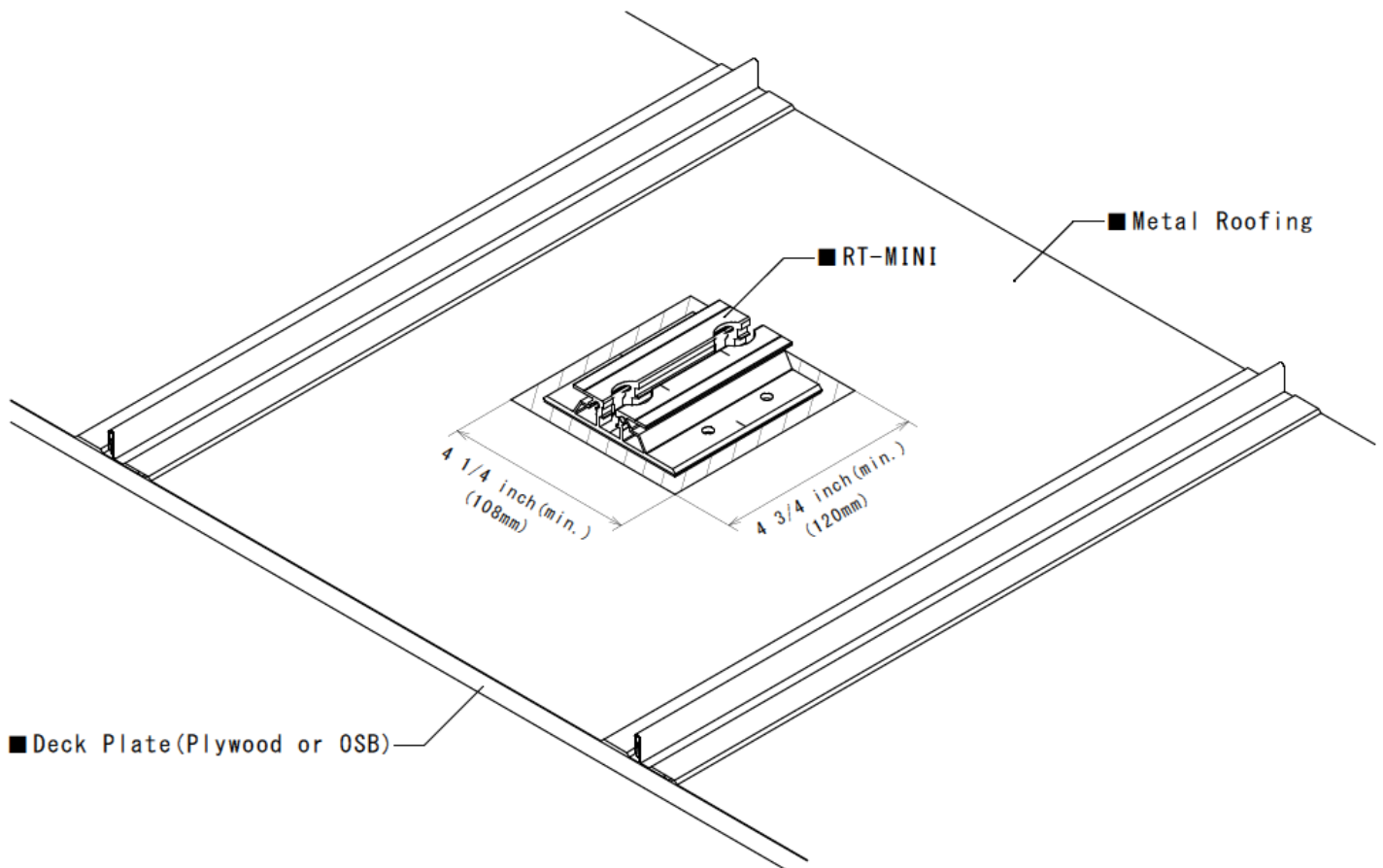

2. Marking on the Roof

(1) Layout

① Mark at ± 35 mm from the intersection of the M Line and Y Line on the M Line.
(See illustrations.)

② In case of Deck Installation, mark at ± 15 mm, ± 25 mm from the intersection of the M Line and Y Line.

③ Then mark at ± 32.5 mm from the M Line

④ Mark at $+ 35$ mm from the Y Line on the M Line.

[Fastening to the Rafter]

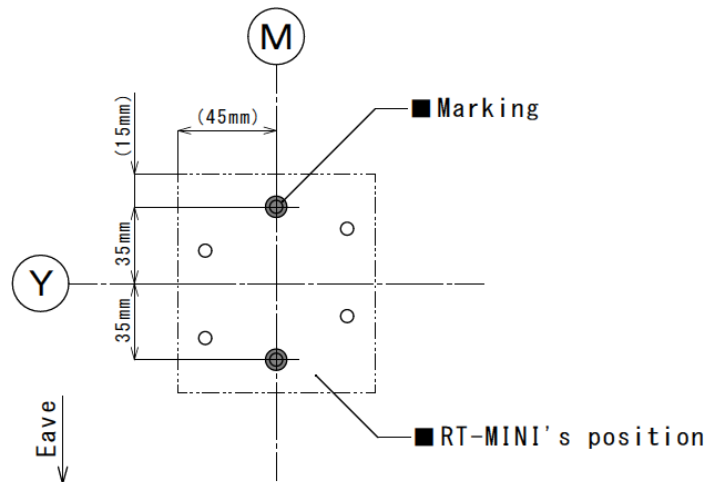

[Fastening to the Deck]

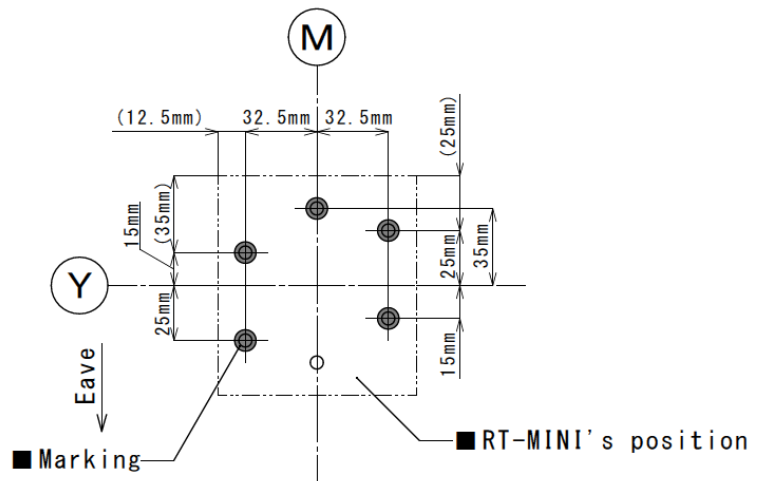

! Attention

Note; Marking spot is not symmetric when MINI base is installed on deck. You may want to have an extra MINI to assist in marking to a metal roof. (Create a MINI JIG by removing the RT Butyl from it.)

3. Bracket Installation

- ① Drill the roofing metal sheet with a $\phi 1/8$ inch ($\phi 3$ mm) drill bit at the markings.

[Fastening it to the Rafter]

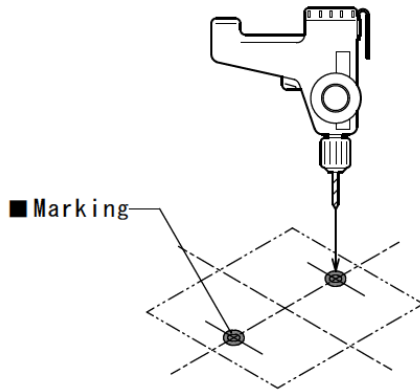

[Fastening it to the Roof Deck]

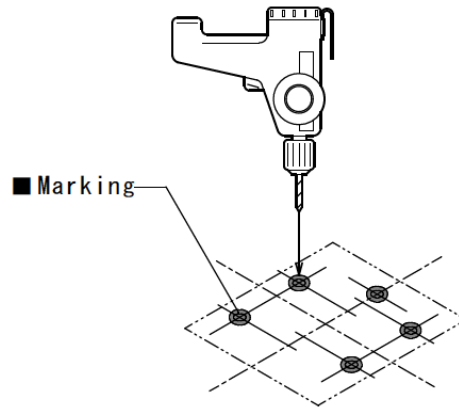

! Attention

Be careful to minimize the intrusion of the drill bit into the sheathing board.

- ② Deburr the edges and fill the drilled hole with roof sealant.

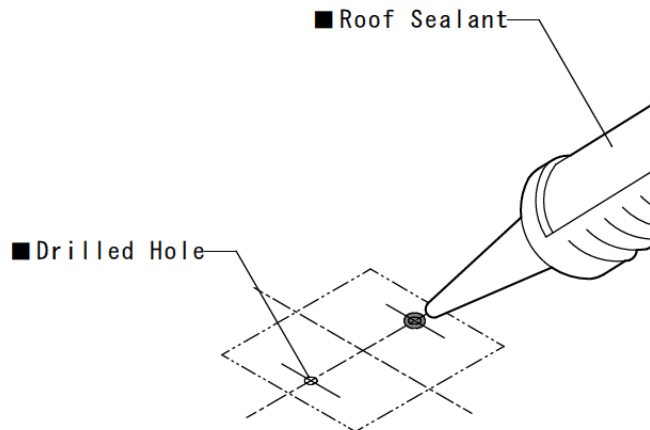

- ③ Peel off the protective paper from the RT butyl tape.

! Attention

Do not leave any protective paper on the surface of the RT butyl tape, it can cause an improper seal and may allow water intrusion under the bracket.

- ④ Place the brackets at the specified location and make sure the RT butyl attaches well to the roofing surface. Set the bracket with 2 ea. (for RAFTER), or 5 ea. (for Roof DECK), of 5.0×60 mm stainless wood screw using 8 mm socket. Slide the M8 or 5/16" Hex bolt into place before fastening the bracket on the roof [rafter install]. After completing process, make sure the brackets are securely fixed.

! Attention

When the MINI base is installed on the deck, 5 screws must be used. The screws are fixed into the side 4 holes and 1 ridge side hole.

Note; Each MINI is shipped with 2 mounting screws. The installer must purchase additional screws when mounting it to the roof deck.

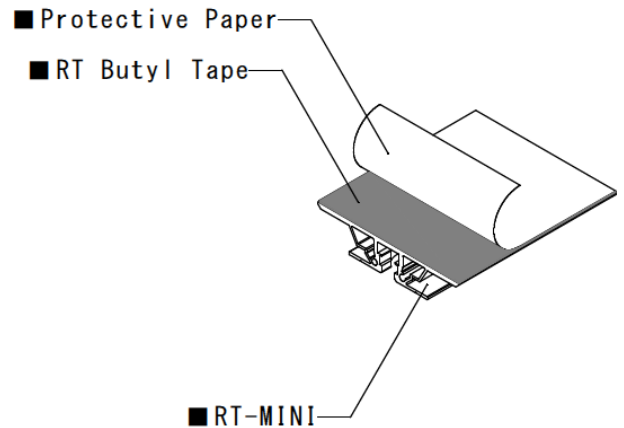

[Fastening to the rafter]

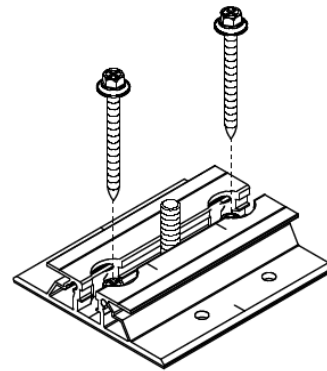

[Fastening to the roof deck]

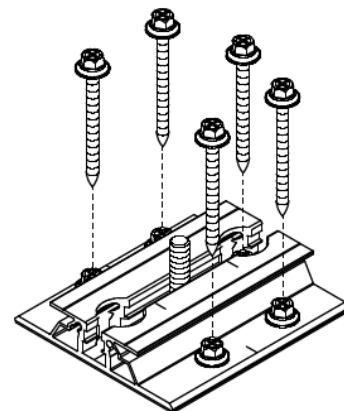

- ⑤ Apply roof sealant around the brackets, the top and each side edge of the brackets.

Cover the exposed RT butyl tape with roof sealant.

Do not apply sealant to the bottom of the brackets.

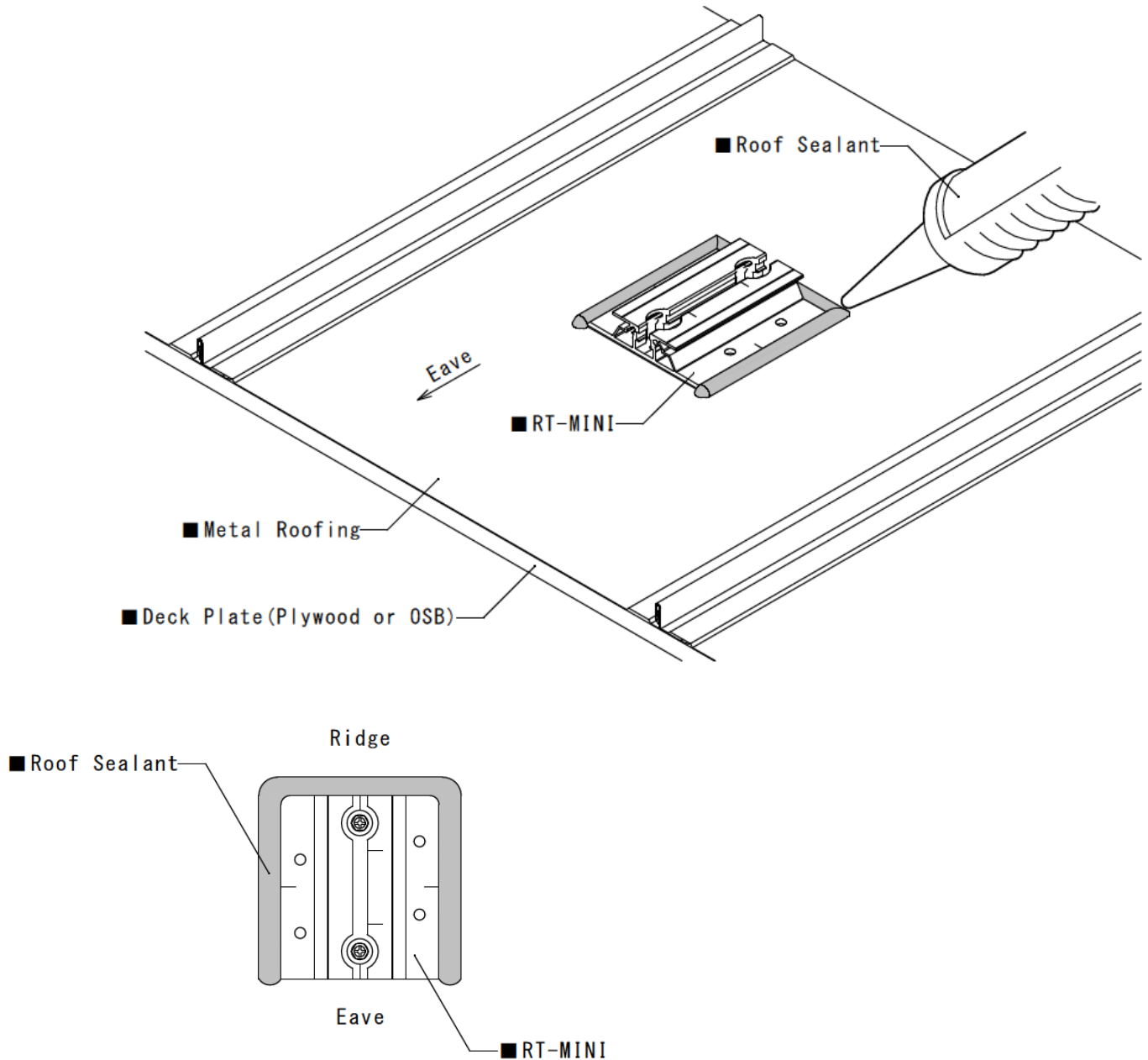

Installation on a Classic rib metal roofing

1. Requirement

- The Roof Tech P.E. Letters are created for a minimum 7/16" OSB with 2x4" rafters 24 in o.c.

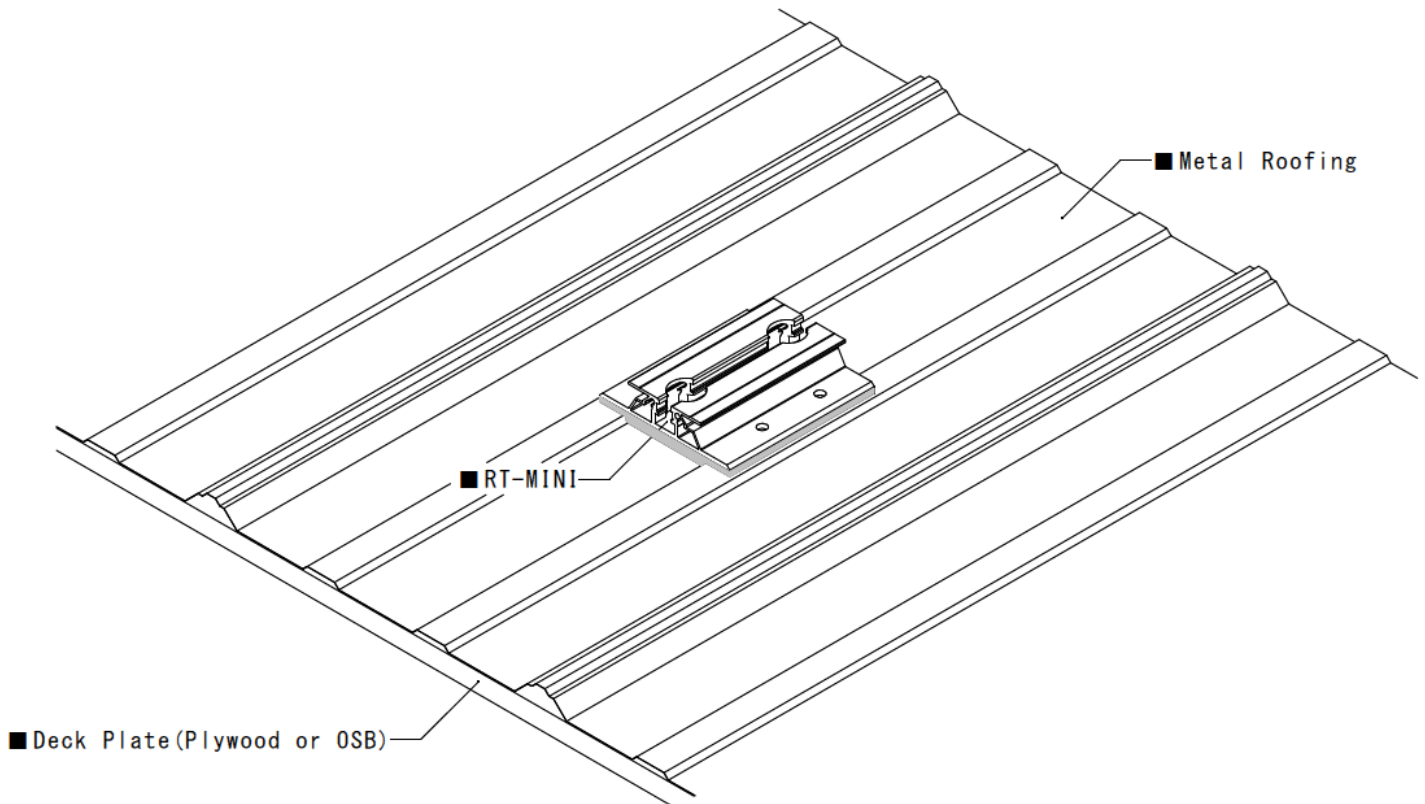

2. Marking on the Roof

(1) Layout

- ① The MINI base must be mounted on the flat surface. Please make sure the location is not on slope surface of metal ribs.
- ② In case of Deck Installation, mark at ± 15 mm, ± 25 mm from the intersection of the M Line and Y Line.

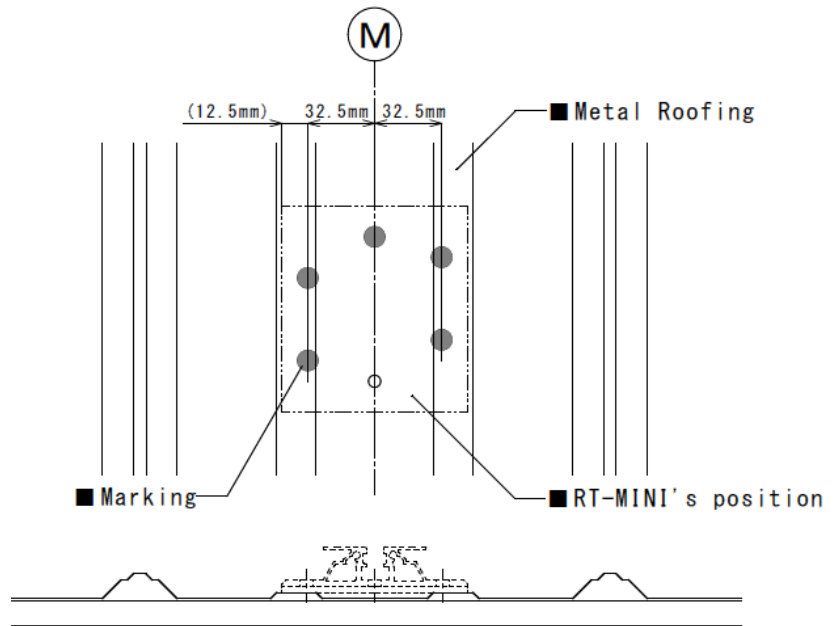

[Fastening to the Deck]

- ③ Then mark at ± 32.5 mm from the M Line
- ④ Mark at $+35$ mm from the Y Line on the M Line.

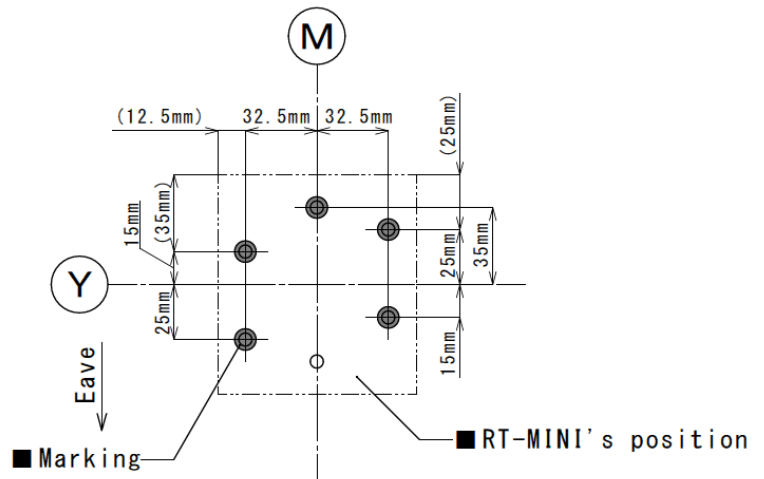

! Attention

Note; Marking spot is not symmetric when MINI base is installed on deck. You may want to have an extra MINI to assist in marking to a metal roof. (Create a MINI JIG by removing the RT Butyl from it.)

3. Bracket Installation

- ① Drill the roofing metal sheet with a ϕ 1/8 inch (ϕ 3 mm) drill bit at the markings.

[Fastening it to the Roof Deck]

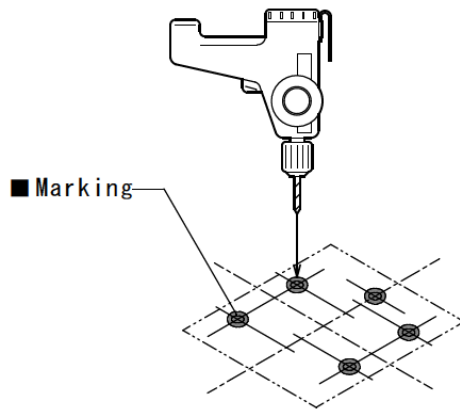

! Attention

Be careful to minimize the intrusion of the drill bit into the sheathing board.

- ② Deburr the edges and fill the drilled hole with roof sealant.

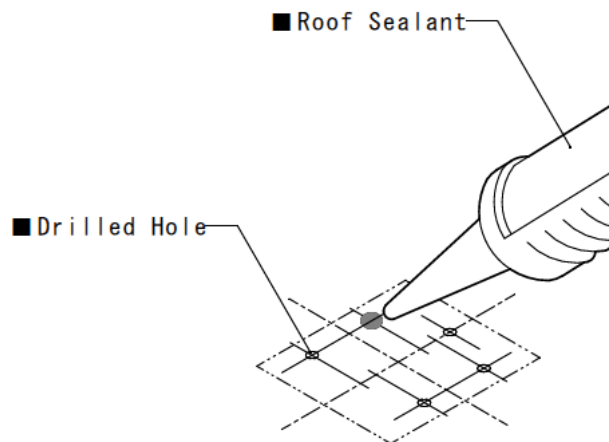

- ③ Please add a butyl pad (RT - Butyl Spacer) on the surface between the ridges.

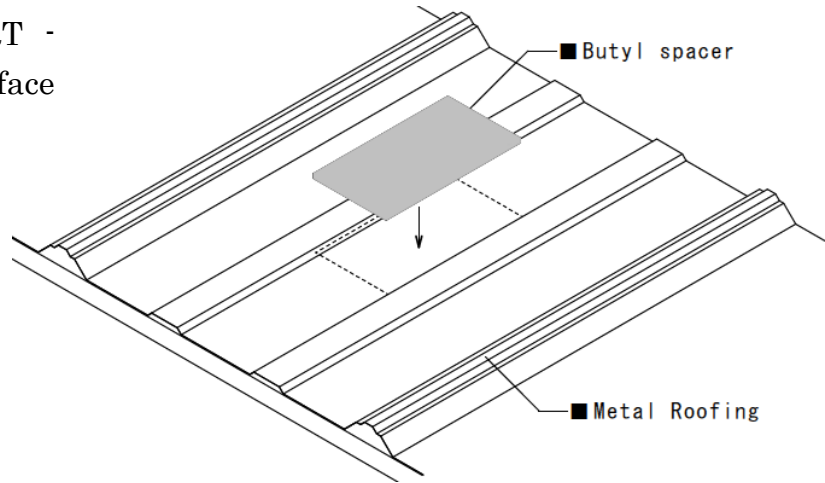
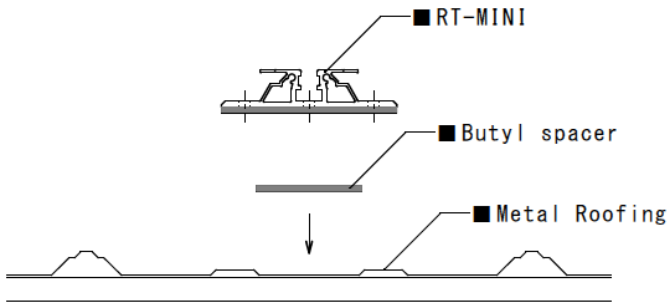

- ④ Peel off the protective paper from the RT butyl tape.

! Attention

Do not leave any protective paper on the surface of the RT butyl tape, it can cause an improper seal and may allow water intrusion under the bracket.

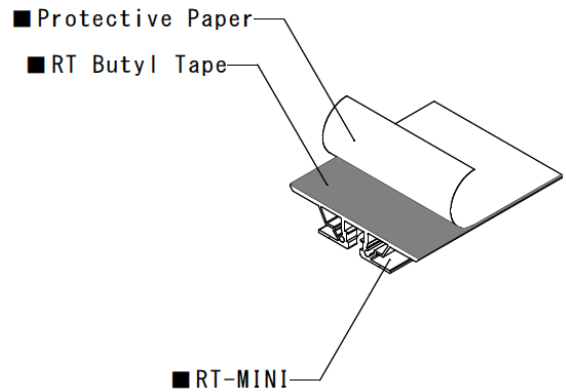

- ⑤ Place the brackets at the specified location and make sure the RT butyl attaches well to the roofing surface.

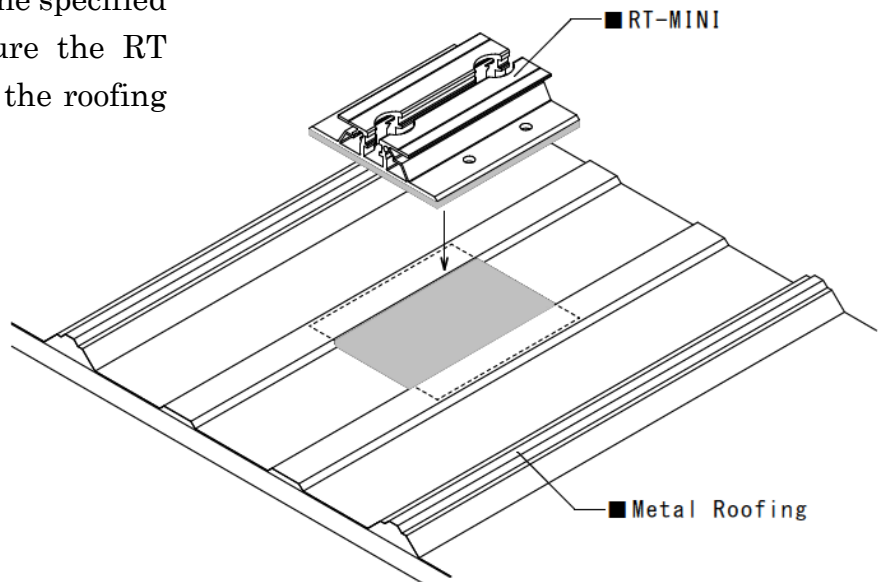

- ⑥ Set the bracket with 5 ea. (for Roof DECK), of 5.0×60 mm stainless wood screw using 8 mm socket. After completing process, make sure the brackets are securely fixed.

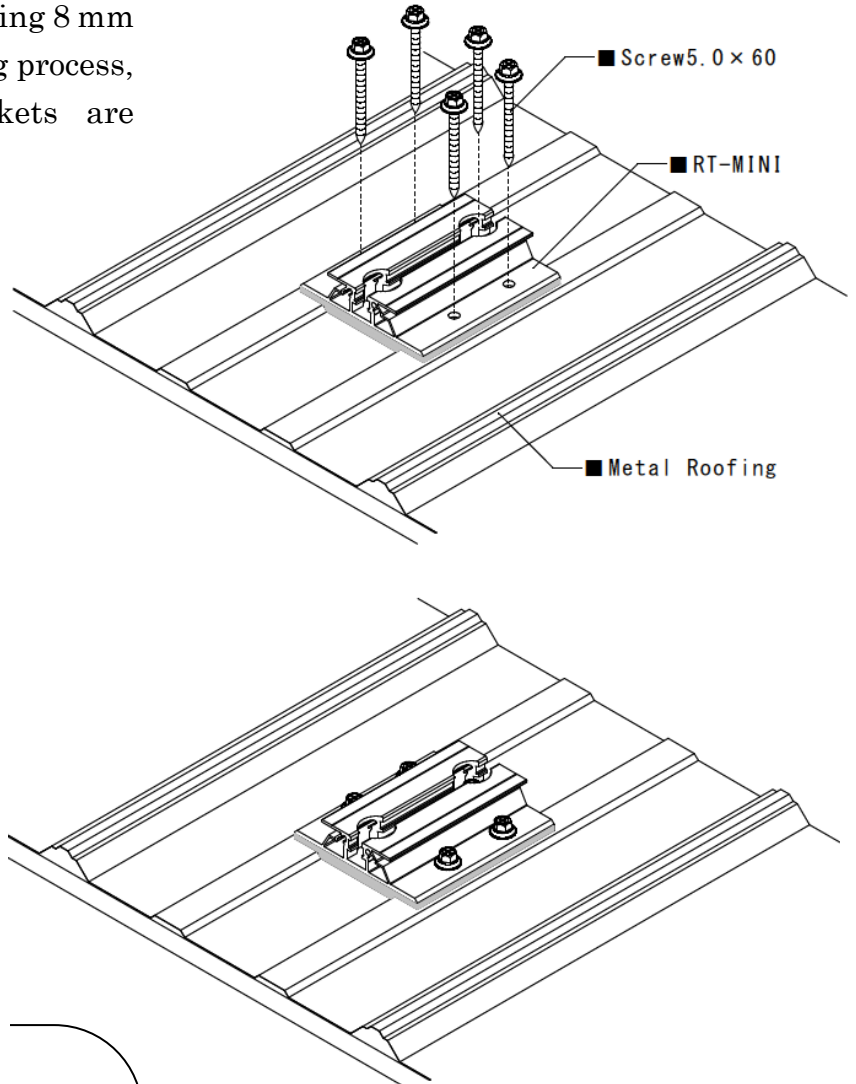

! Attention

When the MINI base is installed on the deck, 5 screws must be used. The screws are fixed into the side 4 holes and 1 ridge side hole.

Note: Each MINI is shipped with 2 mounting screws. The installer must purchase additional screws when mounting it to the roof deck.

- ⑦ Apply roof sealant around the brackets, the top and each side edge of the brackets. In addition, please fill and form a slope and triangle at the ridge side.

Cover the exposed RT butyl tape with roof sealant.

Do not apply sealant to the bottom of the brackets.

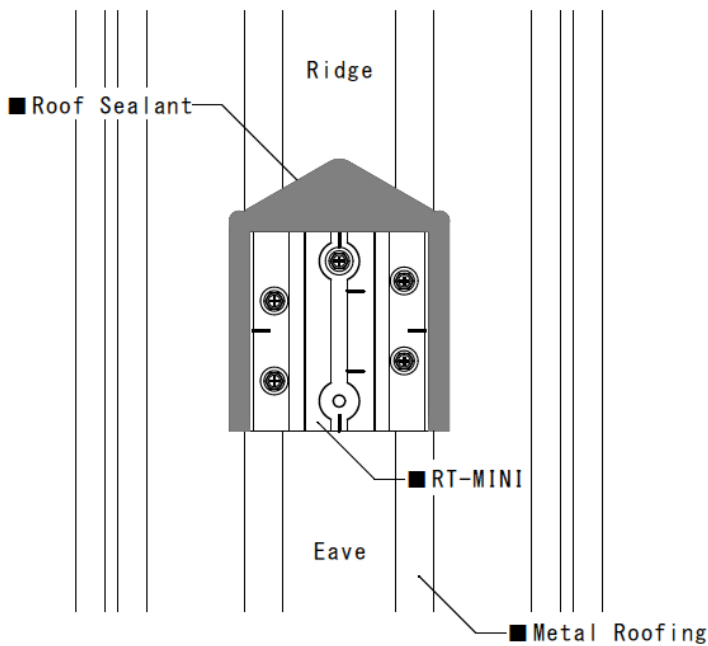
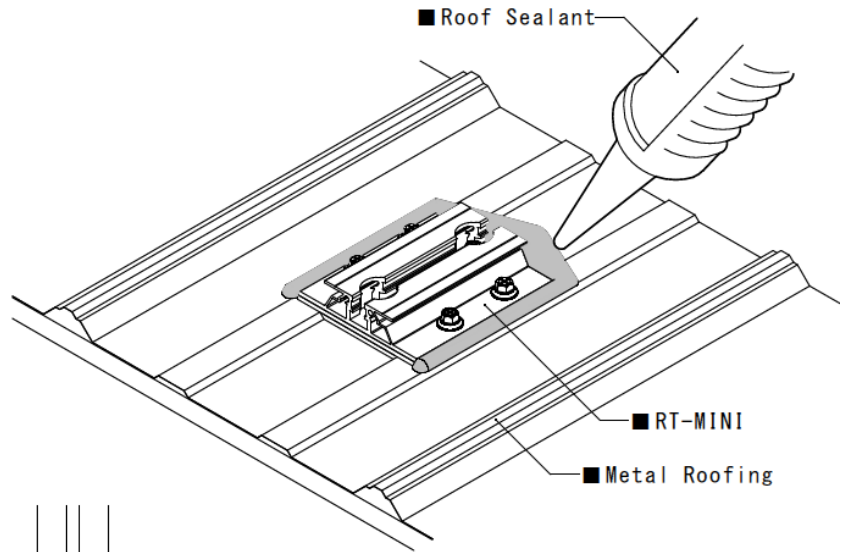

It is important that the designer and installer are acquainted with the PE stamped letters posted on <http://www.roof-tech.us/support>.

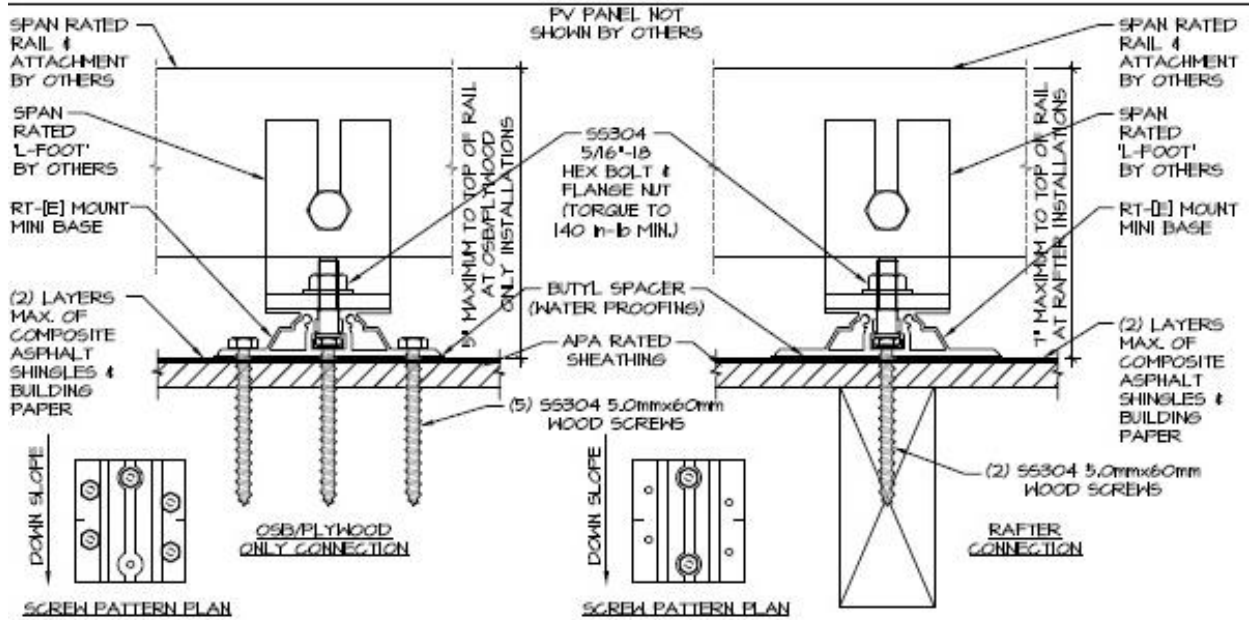

① 'RAIL OPTION' - RAIL AND 'L-FOOT' ORIENTATION
 SCALE: N.T.S.

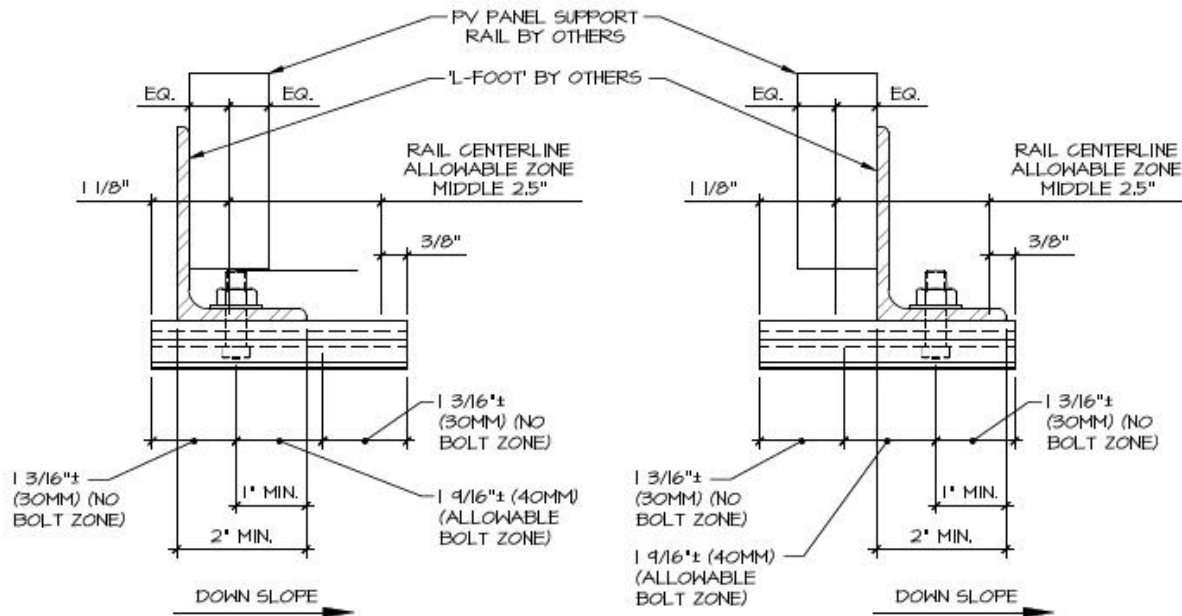

② 'RAIL OPTION' - RAIL AND 'L-FOOT' ORIENTATION
 SCALE: N.T.S.

NOTE: [E] MOUNT MINI BASE TO BE ORIENTED WITH LONG DIRECTION DOWN ROOF SLOPE AS SHOWN. SKIP LOAD ROOF WHERE POSSIBLE TO EVENLY DISTRIBUTE LOAD TO ROOF FRAMING. THERMAL EXPANSION SPLICE RAILS AT 14 FOOT MAXIMUM INTERVALS.

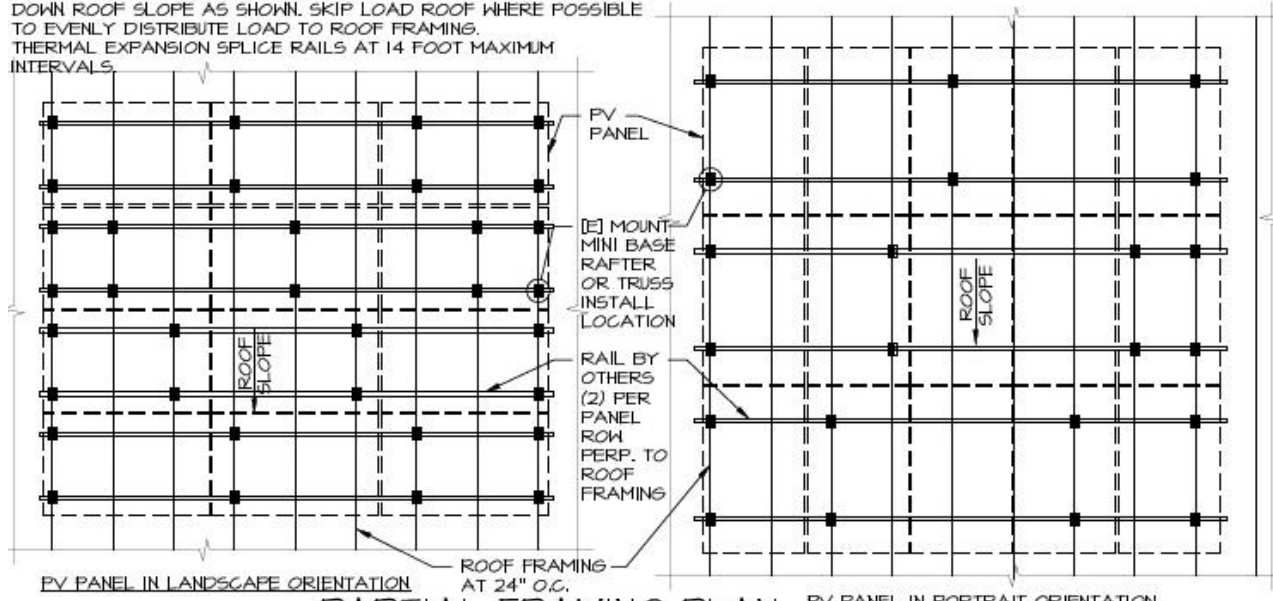

3 PARTIAL FRAMING PLAN (RAFTER INSTALLATION)

SCALE: N.T.S.

Customer Support

For assistance: call Roof-Tech customer support.

(858) 935-6064

<http://roof-tech.us/>

