



System Monitoring
SUNNY SENSORBOX
Installation Manual



Copyright © 2011 SMA America, LLC. All rights reserved.

No part of this document may be reproduced, stored in a retrieval system, or transmitted, in any form or by any means, electronic, mechanical, photographic, magnetic or otherwise, without the prior written permission of SMA America, LLC.

Neither SMA America, LLC nor SMA Solar Technology Canada Inc. makes representations, express or implied, with respect to this documentation or any of the equipment and/or software it may describe, including (with no limitation) any implied warranties of utility, merchantability, or fitness for any particular purpose. All such warranties are expressly disclaimed. Neither SMA America, LLC nor its distributors or dealers nor SMA Solar Technology Canada Inc. nor its distributors or dealers shall be liable for any indirect, incidental, or consequential damages under any circumstances.

The exclusion of implied warranties may not apply in all cases under some statutes, and thus the above exclusion may not apply.)

Specifications are subject to change without notice. Every attempt has been made to make this document complete, accurate and up-to-date. Readers are cautioned, however, that SMA America, LLC and SMA Solar Technology Canada Inc. reserve the right to make changes without notice and shall not be responsible for any damages, including indirect, incidental or consequential damages, caused by reliance on the material presented, including, but not limited to, omissions, typographical errors, arithmetical errors or listing errors in the content material.

All trademarks are recognized even if these are not marked separately. Missing designations do not mean that a product or brand is not a registered trademark.

The *Bluetooth*[®] word mark and logos are registered trademarks owned by Bluetooth SIG, Inc. and any use of such marks by SMA America, LLC and SMA Solar Technology Canada Inc. is under license.

SMA America, LLC
3801 N. Havana Street
Denver, CO 80239 U.S.A.

SMA Solar Technology Canada Inc.
2425 Matheson Blvd. E, 8th Floor
Mississauga, ON L4W 5K5, Canada

IMPORTANT SAFETY INSTRUCTIONS

SAVE THESE INSTRUCTIONS

This manual contains important instructions for Sunny SensorBox system monitoring unit, that must be followed during installation and maintenance of the system monitoring unit.

The Sunny SensorBox is designed and tested according to international safety requirements, but as with all electrical and electronic equipment, certain precautions must be observed when installing and/or operating the Sunny SensorBox. To reduce the risk of personal injury and to ensure the safe installation and operation of the Sunny SensorBox, you must carefully read and follow all instructions, cautions and warnings in this installation guide.

Warnings in this document

A warning describes a hazard to equipment or personnel. It calls attention to a procedure or practice, which, if not correctly performed or adhered to, could result in damage to or destruction of part or all of the SMA equipment and/or other equipment connected to the SMA equipment or personal injury.



DANGER

DANGER indicates a hazardous situation which, if not avoided, will result in death or serious injury.



WARNING

WARNING indicates a hazardous situation which, if not avoided, could result in death or serious injury.



CAUTION

CAUTION indicates a hazardous situation which, if not avoided, could result in minor or moderate injury.

NOTICE

NOTICE is used to address practices not related to personal injury.

Other symbols in this document

In addition to the safety and hazard symbols described on the previous pages, the following symbol is also used in this installation guide:



Information

This symbol accompanies notes that call attention to supplementary information that you must know and use to ensure optimal operation of the system.

General warnings



General warnings

All electrical installations must be done in accordance with the local and *National Electrical Code*[®] ANSI/NFPA 70 or the *Canadian Electrical Code*[®] CSA C22.1. This document does not and is not intended to replace any local, state, provincial, federal or national laws, regulation or codes applicable to the installation and use of the system monitoring unit, including without limitation applicable electrical safety codes. All installations must conform with the laws, regulations, codes and standards applicable in the jurisdiction of installation. SMA assumes no responsibility for the compliance or noncompliance with such laws or codes in connection with the installation of the system monitoring unit.

Before installing or using the Sunny SensorBox, read all of the instructions, cautions, and warnings on the Sunny SensorBox in this installation guide.

Wiring of the Sunny SensorBox must be made by qualified personnel only.

Table of Contents

1	Notes on this manual	11
1.1	Validity	11
1.2	Target group	11
1.3	Storage of the manual	11
1.4	Additional information	11
1.5	Nomenclature	11
2	Safety	12
2.1	Appropriate usage	12
2.2	Safety precautions	14
3	The Sunny SensorBox	15
4	Unpacking	16
4.1	Scope of delivery	16
4.2	Identifying the product	18
4.2.1	Type label	18
4.2.2	Firmware version	18
5	Device overview	19
5.1	Device overview of the Sunny SensorBox	19
5.2	Device overview of the RS485 Power Injector	20
5.3	Device overview of the SMA Power Injector with <i>Bluetooth</i>	21
5.3.1	LED for the power supply	21
5.3.2	LEDs indicating connection quality (<i>Bluetooth</i> LEDs)	22
5.3.3	LED for data communication	23
6	Mounting the device	24
6.1	Sunny SensorBox	24
6.1.1	Requirements for the mounting location	24
6.1.2	Mounting the Sunny SensorBox on a mounting rail	26

6.1.3	Mounting the Sunny SensorBox on rafters	28
6.2	Mounting the temperature sensor on the PV module	30
6.3	RS485 Power Injector	32
6.3.1	Requirements for the mounting location	32
6.3.2	Mounting the RS485 Power Injector on a wall	32
6.4	SMA Power Injector with <i>Bluetooth</i>	34
6.4.1	Requirements for the mounting location	34
6.4.2	Information on SMA <i>Bluetooth</i>	35
6.4.3	Determining the mounting/installation location	36
6.4.4	Mounting the SMA Power Injector with <i>Bluetooth</i> on a wall	38
6.4.5	Mounting the SMA Power Injector with <i>Bluetooth</i> on a top hat rail	39
7	Startup	41
7.1	Information on starting up the device	41
7.2	Connecting the module temperature sensor	41
7.3	Connecting the anemometer	43
7.4	Connecting the ambient temperature sensor	44
7.5	Startup via the RS485-Power Injector	45
7.5.1	Information on starting up the device	45
7.5.2	Connecting the RS485-Power Injector to a RS485 bus node	46
7.5.3	Connecting the RS485 Power Injector to the Sunny SensorBox	48
7.5.4	Connecting the Sunny SensorBox to another Sunny SensorBox	51
7.5.5	Connecting the Sunny SensorBox to an additional RS485 bus node	55
7.5.6	Connecting the RS485 Power Injector to the power supply	57
7.6	Startup via the SMA Power Injector with <i>Bluetooth</i>	58
7.6.1	Information on starting up the device	58
7.6.2	Grounding the Sunny SensorBox	58
7.6.3	Connecting the Sunny SensorBox to the SMA Power Injector with <i>Bluetooth</i>	60
7.6.4	Connecting the SMA Power Injector with <i>Bluetooth</i> to the power supply	63

8	Opening and closing the Sunny SensorBox	66
8.1	Opening the Sunny SensorBox.	66
8.2	Closing the Sunny SensorBox.	66
9	Maintenance and care.	67
9.1	Maintenance.	67
9.2	Terminating the RS485 bus on the Sunny SensorBox.	67
9.3	Connecting the integrated solar radiation sensor	68
9.4	Replacing the gaskets of the Sunny SensorBox	68
9.5	Care	70
10	Decommissioning	71
10.1	Dismantling the Sunny SensorBox.	71
10.2	Dismantling the RS485 Power Injector	71
10.3	Dismantling the SMA Power Injector with <i>Bluetooth</i>	72
10.4	Dismantling the sensors.	72
10.5	Packaging the Sunny SensorBox and sensors	73
10.6	Disposing of the Sunny SensorBox and sensors	73
11	Troubleshooting	74
11.1	Sunny SensorBox	74
11.2	RS485 Power Injector.	75
11.3	SMA Power Injector with <i>Bluetooth</i>	76
12	Parameters	77
12.1	RS485 Power Injector.	77
12.1.1	Display values.	77
12.1.2	Configurable parameters	78
12.2	SMA Power Injector with <i>Bluetooth</i>	79
12.2.1	Display values*	79
12.2.2	Configurable parameters	79

13 Technical Data 80

13.1 Sunny SensorBox 80

13.2 RS485 Power Injector. 81

13.3 SMA Power Injector with *Bluetooth* 82

13.4 Plug-in Power Supply 83

14 Accessories 84

14.1 Mounting plate 84

14.2 Roof bracket 84

14.3 Gasket set for Sunny SensorBox. 85

14.4 RS485 Power Injector. 85

14.5 SMA Power Injector with *Bluetooth* 86

14.6 Anemometer 86

15 Compliance information 87

16 Contact 88

1 Notes on this manual

1.1 Validity

This manual describes the assembly, installation, commissioning and maintenance of the Sunny SensorBox with firmware version 1.51 or higher and hardware version C1 or higher.

This manual does not cover any details concerning equipment connected to the inverter. Information concerning the connected equipment is available from the manufacturer of the equipment.

1.2 Target group

This manual is for qualified personnel. Qualified personnel have received training and have demonstrated skills and knowledge in the construction and operation of this device. Qualified personnel are trained to deal with the dangers and hazards involved in installing electric devices.

1.3 Storage of the manual

Keep this manual in a convenient place for future reference.

1.4 Additional information

Further information about SMA *Bluetooth* Wireless Technology can be found in the download section at www.SMA-America.com.

1.5 Nomenclature

In this document SMA America Production, LLC and SMA Solar Technology Canada Inc. is referred to in the following as SMA.

In this document SMA *Bluetooth*[®] Wireless Technology is referred to in the following as SMA *Bluetooth* Wireless Technology.

2 Safety

2.1 Appropriate usage

Sunny SensorBox

The Sunny SensorBox is a device designed to provide sensor data for SMA communication products via the RS485 Power Injector or the SMA Power Injector with *Bluetooth*.

The Sunny SensorBox must only be used for the purposes described in this manual. This also applies to individual components such as the RS485 Power Injector or SMA Power Injector with *Bluetooth*.

The device is suitable for both private and industrial use. The Sunny SensorBox must only be used in areas defined in the technical specifications.

Only use the original accessories of SMA or accessories recommended by SMA.

Be sure to carefully read the entire manual before starting up the Sunny SensorBox. Store this manual where it can be accessed at all times.

RS485 Power Injector

The RS485 Power Injector is used to integrate the Sunny SensorBox into the RS485 communication bus. The RS485 Power Injector also supplies the Sunny SensorBox with power. A single RS485 Power Injector can power up to five Sunny SensorBoxes.

Up to 50 bus nodes, including the Sunny SensorBox, can be added to an RS485 communication bus.

The RS485 Power Injector supports the following communication products:

- Sunny WebBox
- Sunny Boy Control/Plus with Sunny SensorBox hardware version B2 or higher
- Sunny Data Control

The RS485 Power Injector is intended for indoor installation. All electrical connections are to be carried out by qualified personnel exclusively.

SMA Power Injector with *Bluetooth*

The SMA Power Injector with *Bluetooth* is used to integrate the Sunny SensorBox into an SMA *Bluetooth* network. The Sunny SensorBox supplies measurement data and various parameters to the SMA Power Injector with *Bluetooth*. The device then sends the data to the SMA communication products over the SMA *Bluetooth* network. The SMA Power Injector with *Bluetooth* can be used to bridge gaps in the SMA *Bluetooth* network, which can also be done using the SMA *Bluetooth* Repeater. The SMA Power Injector with *Bluetooth* also supplies the Sunny SensorBox with power. You can only operate one Sunny SensorBox with the SMA Power Injector with *Bluetooth*.

However, you can add multiple SMA Power Injectors with *Bluetooth* to an SMA *Bluetooth* network and have each one connected to a separate Sunny SensorBox. An SMA *Bluetooth* network can accommodate the following number of nodes:

- If one master* device is used, then you can connect up to 50 devices, including one or more Sunny SensorBoxes.
- If two master devices are used, you can connect up to 25 devices, including one or more Sunny Sensor Boxes.



The SMA Power Injector with *Bluetooth* supports the following communication products:

- Sunny WebBox with *Bluetooth* Wireless Technology.
- A *Bluetooth*-enabled computer and the Sunny Explorer software program, version 1.1.11 or higher.
- All the SMA *Bluetooth* products described in manuals for communication products are supported to ensure SMA *Bluetooth* wireless connectivity.
- The Sunny Beam with *Bluetooth* is not supported.

The SMA Power Injector with *Bluetooth* is intended for indoor installation. All electrical connections must be carried out by qualified personnel.

* Master is a term used in network technology. In a network, a master is a device that prompts other devices (slaves) to perform a specific task such as receiving or sending data. In an SMA *Bluetooth* network, all SMA communication products (e.g., Sunny Explorer, Sunny Beam with *Bluetooth*, etc.) are master devices.

2.2 Safety precautions

<p> DANGER</p> <p>High voltages are present in the Sunny Boy during operation. Death or serious injury due to electric shock.</p> <ul style="list-style-type: none"> • All work on the Sunny Boy must only be carried out by qualified personnel.
<p> DANGER</p> <p>Falling from high altitude when mounting and installing the Sunny SensorBox. Death or serious injury will result.</p> <ul style="list-style-type: none"> • All work on rooftops must only be carried out by qualified personnel.
<p> CAUTION</p> <p>Overvoltage in case of lightning strike. Fire and damage to connected devices will result.</p> <ul style="list-style-type: none"> • Integrate the Sunny SensorBox into the lightning protection system, if existing.
<p>NOTICE</p> <p>Electrostatic discharges. Internal components of the device can be damaged irreparably by electrostatic discharge.</p> <ul style="list-style-type: none"> • Ground yourself before working on the device. • Avoid touching any connectors or plug contacts.
<p>NOTICE</p> <p>Ingress of water into the open Sunny SensorBox. Damage to the Sunny SensorBox will result.</p> <ul style="list-style-type: none"> • Before working on the device unplug the plug-in power supply unit. • When working outdoors, avoid water, rain or snow to enter the Sunny SensorBox.

3 The Sunny SensorBox

With the Sunny SensorBox and the external sensors, you can collect environmental data from your PV system which is then used for performance monitoring.

To this end, the Sunny SensorBox comes with an integrated solar radiation sensor and an external module temperature sensor. You also have the option of connecting an ambient temperature sensor and an anemometer to the Sunny SensorBox.

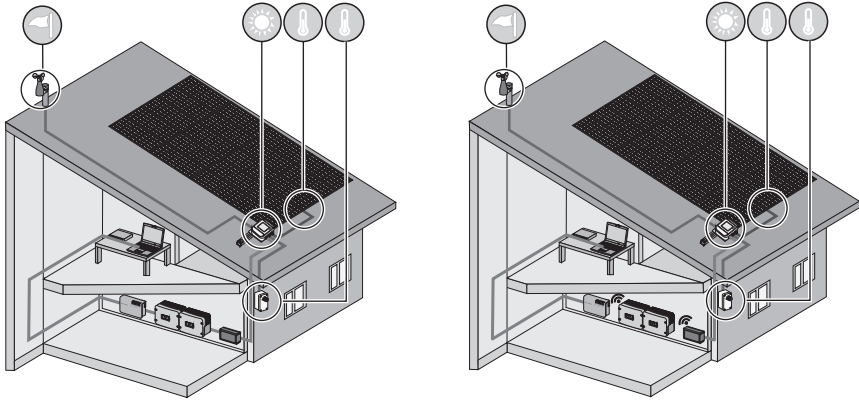

You can compare radiation levels and PV power based on the radiation intensity (W/m^2) measured by the integrated solar radiation sensor and the total amount of recorded power the PV system generates in a single day. If this data is observed over a longer period, then this solution offers a practical method of identifying any errors in your PV system. Sunny Portal (www.sunnyportal.com) or Flashview can be used to visualize the data collected by the Sunny SensorBox.

4 Unpacking

4.1 Scope of delivery

Check the delivery for completeness and signs of damage. Please contact your dealer if the delivery is not complete or you find any damage.

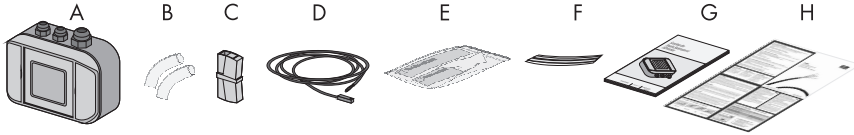

Position	Quantity	Designation
A	1	Sunny SensorBox with integrated solar radiation sensor
B	2	Insulating tubes
C	1	Terminal
D	1	PT100 module temperature sensor with 8 ft. (2.5 m) connection cable
E	1	Thermally conductive adhesive (protective gloves, hardener and binder)
F	2	Adhesive strips
G	1	Installation guide
H	1	RS485 cabling plan poster

RS485 Power Injector

Only with Sunny SensorBox order option: SUNNYSSENSOR-1xxx

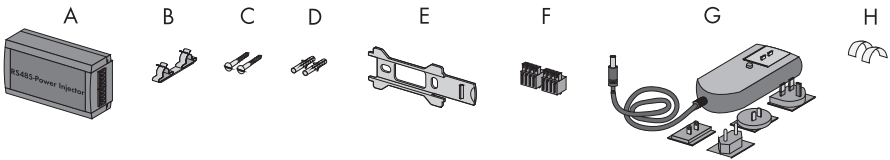

Position	Quantity	Designation
A	1	RS485 Power Injector
B	1	Shield clamp
C	2	Screws
D	2	Wall anchors
E	1	Wall mounting bracket
F	2	4-pole plugs
G	1	Plug-in power supply with plug adapter
H	2	Conductive adhesive films

SMA Power Injector with Bluetooth

Only with Sunny SensorBox order option: SUNNYSSENSOR-2xxx, SUNNYSSENSOR-3xxx

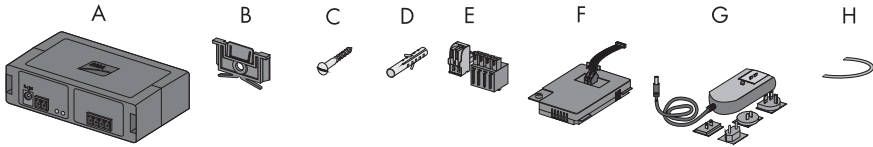

Position	Quantity	Designation
A	1	SMA Power Injector with <i>Bluetooth</i>
B	1	Bracket for wall or top hat rail*
C	1	Screw
D	1	Wall anchor
E	1	Plug (1 x 2 poles, 1 x 4 poles)
F	1	Power module for supplying power (scope of delivery listed in power module installation guide) - only with order option SUNNYSSENSOR-3xxx
G	1	Plug-in power supply with plug adapter - only with order option SUNNYSSENSOR-2xxx
H	1	Grounding cable

* Can be found on the back of the SMA Power Injector with *Bluetooth* on delivery.

Module frame mounting plate

Only with Sunny SensorBox order option: SUNNYSSENSOR-x1xx

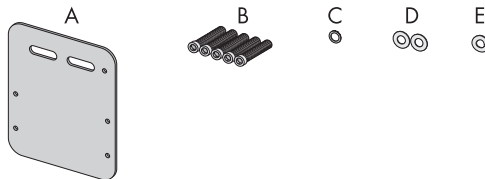

Position	Quantity	Designation
A	1	Mounting plate
B	5	Hexagonal screws*
C	1	Contact washer*
D	2	Washers*
E	1	Locking washer*

* Pre-mounted on delivery.

4.2 Identifying the product

4.2.1 Type label

Sunny SensorBox

You can identify the Sunny SensorBox by the type label. The type label can be found on the bottom of the device.

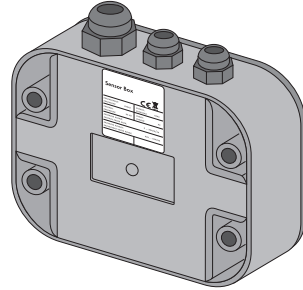

RS485 Power Injector

You can identify the RS485 Power Injector by the type label. The type label can be found on the bottom of the device.

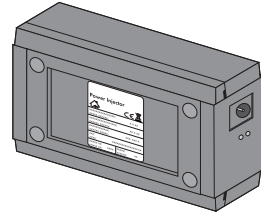

SMA Power Injector with Bluetooth

You can identify the SMA Power Injector with *Bluetooth* by the type label. The type label can be found on the right side of the device.

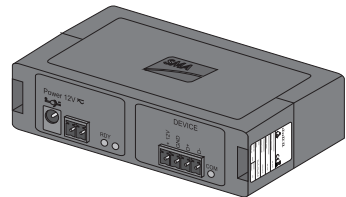

4.2.2 Firmware version

The firmware version of the Sunny SensorBox is displayed by the communication product (e.g., the Sunny WebBox or Sunny Explorer) as follows:

- Via the "FwVer" display option for the RS485 Power Injector. To enable this option, select the "Parameters" tab from the "Devices" navigation bar.
- Via the "Settings" device menu for the SMA Power Injector with *Bluetooth*. To enable this option, select the "Type label > Central components" subgroup in the "Device components" parameter group.

5 Device overview

5.1 Device overview of the Sunny SensorBox

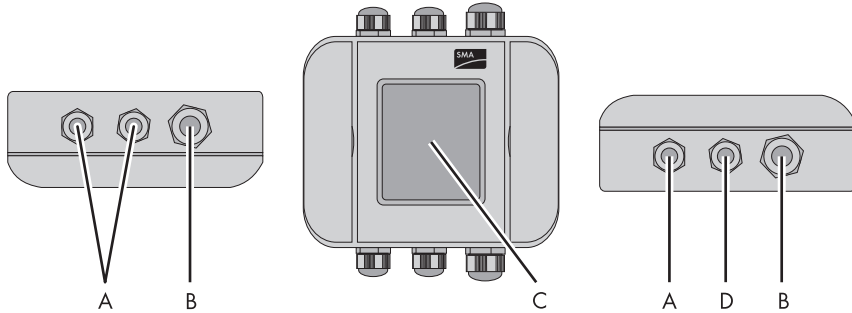

Position	Designation
A	cable opening for the sensors
B	cable opening for connecting the RS485 Power Injector or SMA Power Injector with <i>Bluetooth</i>
C	integrated solar radiation sensor
D	cable opening for grounding the Sunny SensorBox

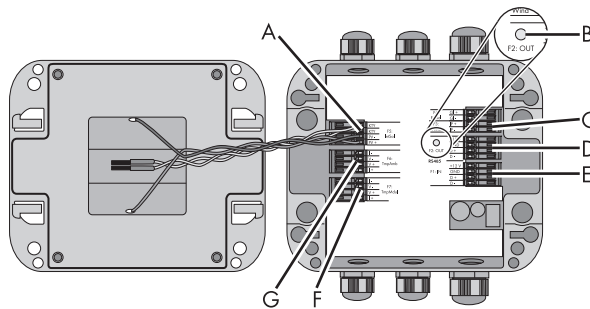

Position	Designation	Meaning
A	"F5: IntSol"	connection terminal for the integrated solar radiation sensor
B	LED of the Sunny SensorBox	LED for the status display of the Sunny SensorBox
C	"F3: Wind"	connection terminal for the anemometer
D	"RS485 F2: OUT"	connection terminal for additional RS485 bus nodes
E	"RS485 F1: IN"	connection terminal for the RS485 Power Injector or SMA Power Injector with <i>Bluetooth</i>

Position	Designation	Meaning
F	"F7: TmpMdul"	connection terminal for the module temperature sensor
G	"F6: TmpAmb"	connection terminal for the ambient temperature sensor

LED of the Sunny SensorBox

Status	Meaning
Off	<ul style="list-style-type: none"> The Sunny SensorBox does not have power. during startup, the LED is switched off for 10 seconds during a reset, the LED is switched off for 60 seconds
Glows continuously	Sunny SensorBox is connected to the power supply and ready for operation.
Flashes 2 times quickly	Sunny SensorBox is connected to the power supply and receiving data over the RS485 communication channel.
Flashes every second	firmware malfunction (see section 11 "Troubleshooting" (page 74)).

5.2 Device overview of the RS485 Power Injector

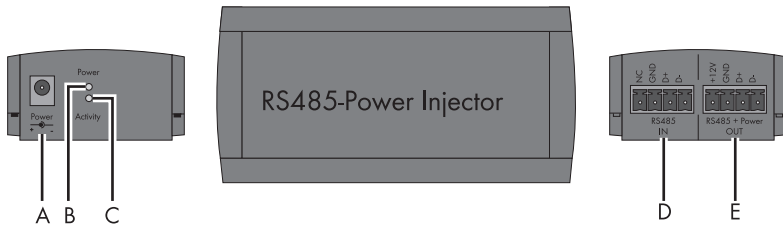

Position	Designation	Meaning
A	"Power"	connection for the plug-in power supply
B	"Power" LED	LED for the Power Supply
C	"Activity" LED	LED for data traffic
D	"RS485 IN"	connection for the RS485 communication bus
E	"RS485 + Power OUT"	connection for the Sunny SensorBox

5.3 Device overview of the SMA Power Injector with Bluetooth

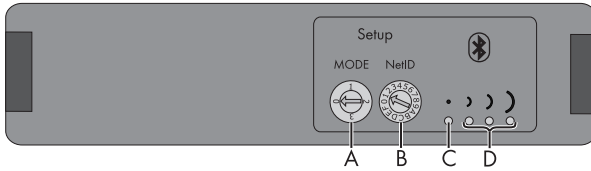

Position	Designation	Meaning
A	"MODE"	rotary switch for the operating mode
B	"NetID"	rotary switch for the NetID
C	Bluetooth LED (blue)	LEDs for indicating the connection quality
D	Bluetooth LEDs (yellow)	

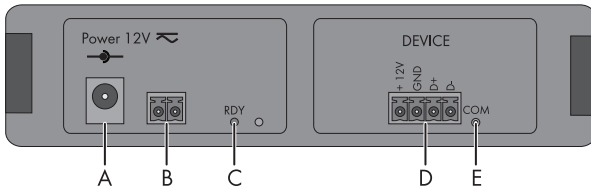









Position	Designation	Meaning
A	"Power 12V ≈ "	connection for the plug-in power supply, polarity is arbitrary
B	2-pole plug	connection for the alternate power supply, polarity is arbitrary
C	"RDY" LED (green)	LED for the power supply
D	"DEVICE"	connection for the Sunny SensorBox
E	"COM" LED (yellow)	LED for data communication





5.3.1 LED for the power supply

RDY LED (green)	
Status	Meaning
Glows continuously	supply voltage is ok, device is in operation
Flashes	supply voltage is borderline, although the device is running, stable operation is not guaranteed
Off	supply voltage is either not available or too low, device is not running

5.3.2 LEDs indicating connection quality (*Bluetooth* LEDs)

The SMA Power Injector with *Bluetooth* must be added to an existing *Bluetooth* network before it can display the connection quality. The *Bluetooth* network can only be set up using communication products (e.g., Sunny WebBox with *Bluetooth* or Sunny Explorer).

Bluetooth LEDs		Connection quality	Action
Status			
Blue LED	Yellow LEDs		
 Permanently on	 3 LEDs on	very good	No action required.
	 2 LEDs on	good	No action required.
	 1 LED on	unreliable	Change the positioning or install an SMA <i>Bluetooth</i> Repeater.
	 no LEDs on	critical	
 Off	 no LEDs on	none	The SMA Power Injector with <i>Bluetooth</i> is not connected to the <i>Bluetooth</i> network: <ul style="list-style-type: none"> • There is no device with the same NetID within the radio range. <ul style="list-style-type: none"> - Check the NetID. - Change the positioning or install an SMA <i>Bluetooth</i> Repeater (see page 35). • The <i>Bluetooth</i> network has not been established. Only communication products can initiate network establishment.
	 3 LEDs flashing	(special function)	The rotary switch for the "NetID" is set to position "1" or "0" (see section 6.4.3 "Determining the mounting/ installation location" (page 36)).

Bluetooth LEDs			
Status		Connection quality	Action
Blue LED	Yellow LEDs		
 Flashes	 3 LEDs on	very good	Installation mode The SMA Power Injector with <i>Bluetooth</i> is in installation mode ("MODE 3"). The sole purpose of this position is to determine the location of installation (see section 6.4.3 "Determining the mounting/installation location" (page 36)). To exit the installation mode, turn the "MODE" rotary switch to position "0", "1" or "2".
	 2 LEDs on	good	
	 1 LED on	unreliable	
	 no LEDs on	critical	

5.3.3 LED for data communication

COM LED (yellow)	
State	Meaning
Flashes	communication between the Sunny SensorBox and the SMA Power Injector with <i>Bluetooth</i> .
Off	no communication between the Sunny SensorBox and the SMA Power Injector with <i>Bluetooth</i>

6 Mounting the device

	DANGER
<p>Falling from high altitude when mounting and installing the Sunny SensorBox. Death or serious injury will result.</p> <ul style="list-style-type: none">• All work on rooftops must only be carried out by qualified personnel.	

6.1 Sunny SensorBox

6.1.1 Requirements for the mounting location

	CAUTION
<p>Overvoltage in case of lightning strike. Fire and damage to connected devices will result.</p> <ul style="list-style-type: none">• Integrate the Sunny SensorBox into the lightning protection system.	

Mount the Sunny SensorBox either on the mounting rails of the PV mounting system or on rafters. Observe the following information concerning the mounting location of the Sunny SensorBox:

- The Sunny SensorBox is suitable for outdoor installation.
- The ambient temperature must remain between $-13\text{ }^{\circ}\text{F}$ and $+158\text{ }^{\circ}\text{F}$ ($-25\text{ }^{\circ}\text{C}$ and $+70\text{ }^{\circ}\text{C}$).
- If you want to use the integrated solar radiation sensor, make sure the Sunny SensorBox is mounted at the same tilt angle and orientation as the PV module so that the sensor readings you obtain can be directly compared to the yield of the PV system.
- Which mounting location to choose depends on which sensors are used. Observe the cable lengths specified in the sensor manual.
- The maximum cable length from the final Sunny SensorBox to the RS485 Power Injector is 490 ft. (150 m).
- The maximum cable length from the Sunny SensorBox to the SMA Power Injector with *Bluetooth* is 490 ft. (150 m).

- As depicted below, the Sunny SensorBox must be mounted in three different alignments to keep water from entering and damaging the device. The Sunny SensorBox must not be mounted vertically with the SMA logo on the top, as this would allow water to penetrate into the device through the ventilation membrane.

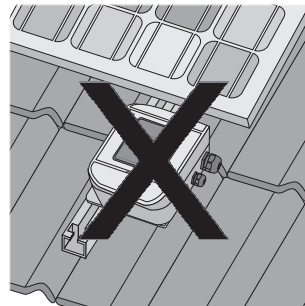
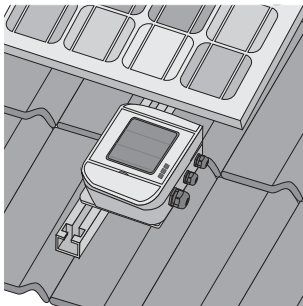
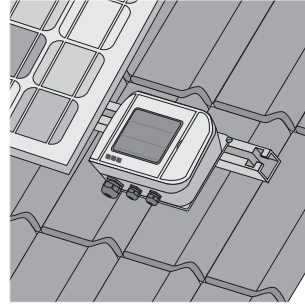
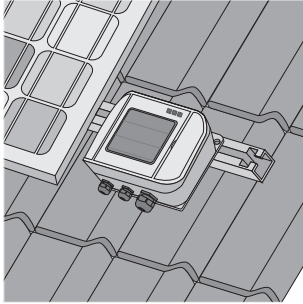

6.1.2 Mounting the Sunny SensorBox on a mounting rail

Included mounting accessories

Only with Sunny SensorBox order option: SUNNYSSENSOR-x1xx

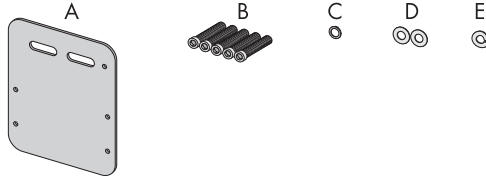

Position	Quantity	Designation
A	1	Mounting plate
B	5	M4 hexagonal screws*
C	1	M4 contact washer*
D	2	Washers*
E	1	Locking washer*

* Pre-mounted on delivery.

Mounting the Sunny SensorBox on a mounting rail

You can mount the device on a module frame provided the mounting rail protrudes from beneath the sides of the modules by approximately 6 in. (160 mm).

1. The mounting location must be determined based on the amount of space available and the prescribed orientation of the Sunny SensorBox (see page 24).

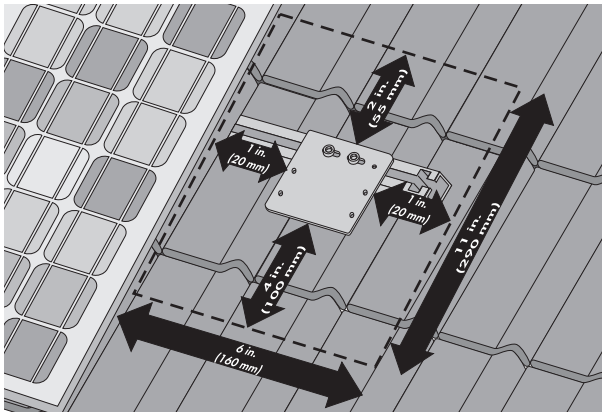

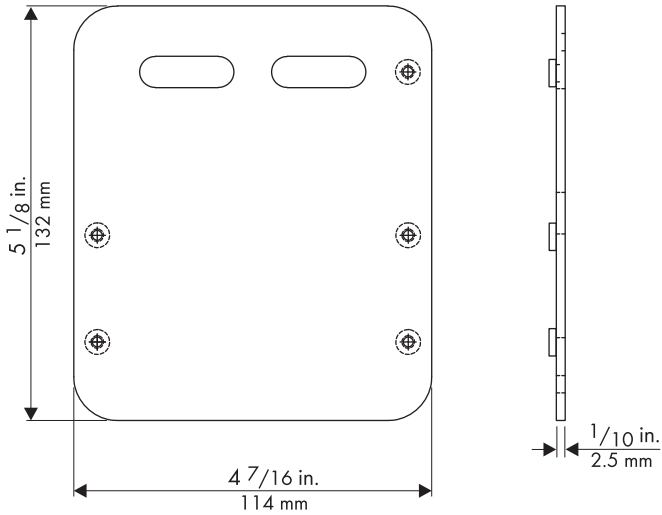

- 2. Attach the mounting plate onto the module rail with the screws and slot nuts provided by the manufacturer of the PV mounting system. Usually any screw up to M10 in size fits into the slot nuts.

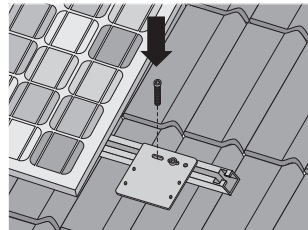

- 3. Open the side flaps of the Sunny SensorBox using the notches as a guide.
 - 4. Fasten the Sunny SensorBox onto the mounting plate with four hexagonal screws. Make sure the Sunny SensorBox is oriented correctly (see page 24).
- The Sunny SensorBox is now attached to the mounting rail.

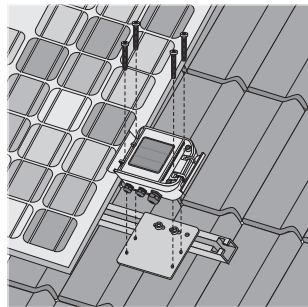

6.1.3 Mounting the Sunny SensorBox on rafters

Optional mounting accessories

SMA order number: Roofan-Sensor

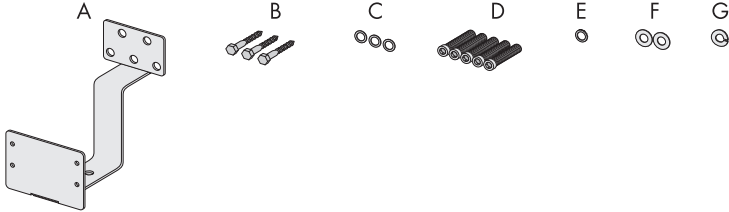

Position	Quantity	Designation
A	1	Roof bracket
B	3	Hexagonal wood screws
C	3	Washers for hexagonal wood screws
D	5	M4 hexagonal screws*
E	1	M4 contact washer*
F	2	Washers*
G	1	Locking washer*

* Pre-mounted on delivery.

Mounting the Sunny SensorBox on rafters

To mount the device on a rafter, you first need the optional roof bracket (see section 1.4 "Accessories" (page 84)).

1. The mounting location should be determined based on the amount of space available and the prescribed orientation of the Sunny SensorBox (see page 24).

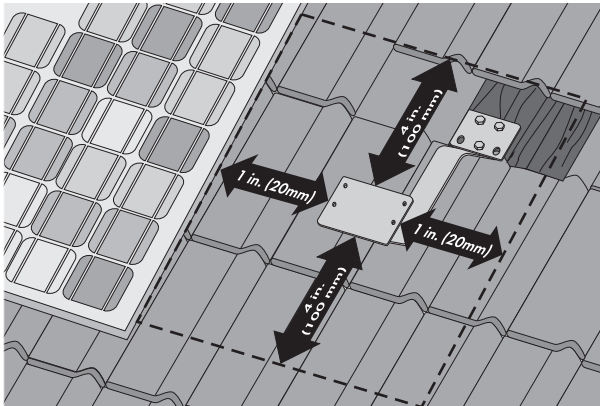

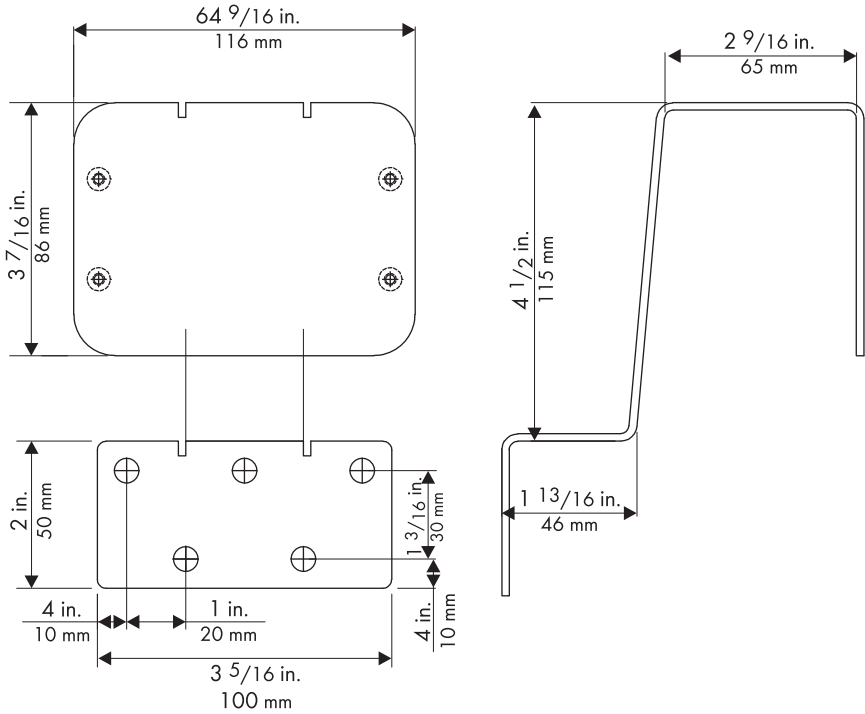

2. Uncover the rafters by removing the roof tiles in the mounting area.
3. Attach the roof bracket to the rafter using the three wood screws and corresponding washers.

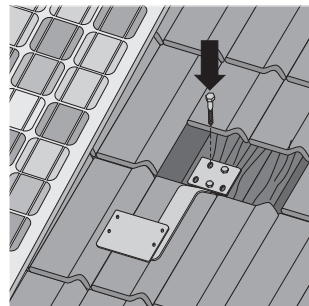

4. Incorporate the roof bracket into the existing lightning protection system.

A means for attaching the lightning protection unit can be found on the lower slope of the roof bracket (see page 59).

5. Using the notches as a guide, open the side flaps of the Sunny SensorBox.
6. Fasten the Sunny SensorBox onto the mounting bracket with four hexagonal screws. Make sure the Sunny SensorBox is oriented correctly (see page 24).

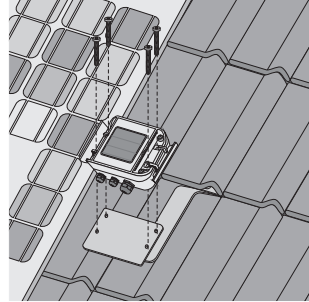

7. Grind down the roof tiles if necessary.
8. Put the roof tiles back on the roof.
- The Sunny SensorBox is now mounted on the rafter.

6.2 Mounting the temperature sensor on the PV module

Requirements for the mounting location

Observe the following requirements regarding the mounting location of the module temperature sensor:

- Select a PV module that remains unshaded throughout the day.
- Do not attempt to extend or shorten the pre-assembled 8 ft. (2.5 m) cable.
- The module temperature sensor is affixed to the back of the PV module.

Included mounting accessories

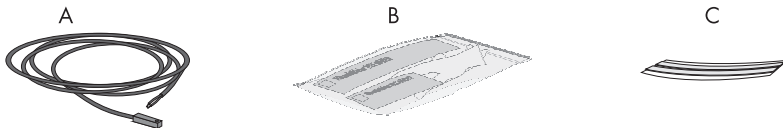

Position	Quantity	Designation
A	1	PT100 module temperature sensor with 8 ft. (2.5 m) connection cable
B	1	Thermally conductive adhesive (protective gloves, hardener and binder) with instructions and packaging
C	2	Adhesive strips

Mounting the temperature sensor on the PV module



CAUTION

Risk of chemical burns from contact with the thermally conductive adhesive.

- Avoid any contact with the skin, mucous membranes and eyes.
- Wear appropriate protective clothing, gloves and goggles when working on the sensor.
- Follow the safety precautions and instructions from the manufacturer of the thermally conductive adhesive.

1. The mounting location must be determined based on the cable length of the sensor and the applicable site requirements.

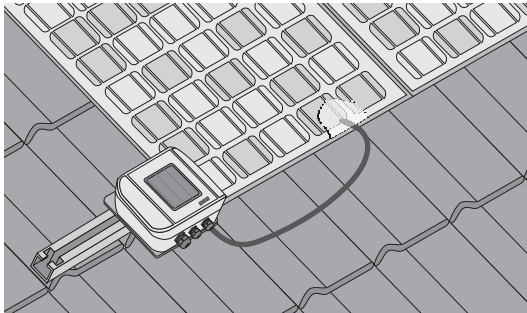

2. Prepare the thermally conductive adhesive included in the delivery according to the instructions of the manufacturer. Observe the processing and hardening times specified by the manufacturer.
3. Affix the module temperature sensor to the bottom of a PV module using the thermally conductive adhesive.
4. Using strips of adhesive tape, affix the module temperature sensor and the cable to the bottom of the PV module.

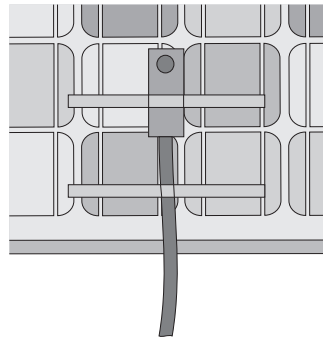

5. Once the thermally conductive adhesive is hardened, remove the adhesive tape strips.
 - The module temperature sensor is now mounted.

6.3 RS485 Power Injector

6.3.1 Requirements for the mounting location

Observe the following requirements regarding the mounting location of the RS485 Power Injector:

- The RS485 Power Injector is intended for indoor installation only.
- The mounting location must be in the vicinity of a 100 V ... 240 V socket (power supply cable length 6 ft. (1,800 mm)).
- Protect the RS485 Power Injector from dust, moisture and corrosive substances.
- The ambient temperature must remain between - 13 °F and +149 °F (- 20 °C and + 65 °C).
- The maximum cable length from the final Sunny SensorBox to the RS485 Power Injector is 490 ft. (150 m).
- The maximum cable length of the entire RS485 communication bus is 3,900 ft. (1,200 m).

6.3.2 Mounting the RS485 Power Injector on a wall

Included mounting accessories

Only with Sunny SensorBox order option: SUNNYSSENSOR-1xxxx

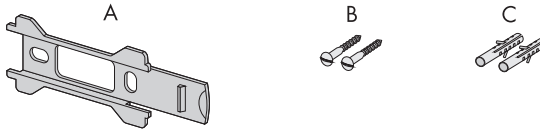

Position	Quantity	Designation
A	1	Wall mounting bracket
B	2	Screws
C	2	Wall anchors

Mounting the RS485 Power Injector

1. Determine the mounting location based on the amount of available space.

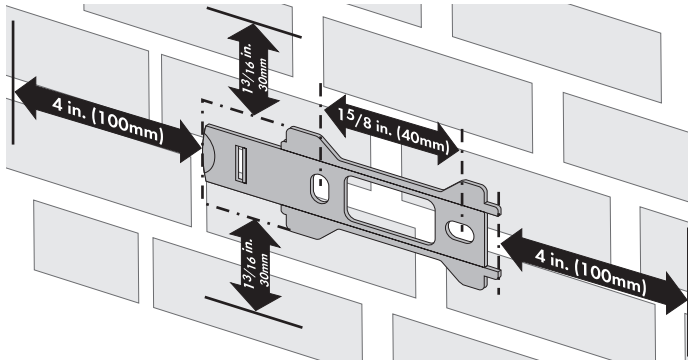

DANGER

Drilling into live cables.

Death or serious injury due to electric shock.

- Before drilling the holes, check whether electricity cables run through the walls at the desired mounting location. If cables run through the walls at the desired mounting location, then select a different mounting location.

2. Mark the position of the drill holes using the wall mounting bracket as a guide.
3. Drill holes with a diameter of $\frac{1}{2}$ in. (6 mm) at the marked points and insert the wall anchors.
4. Attach the wall mounting bracket to the wall with two screws.

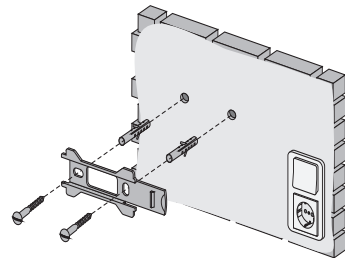

5. Slide the RS485 Power Injector onto the wall mounting bracket as shown in steps ① - ③.

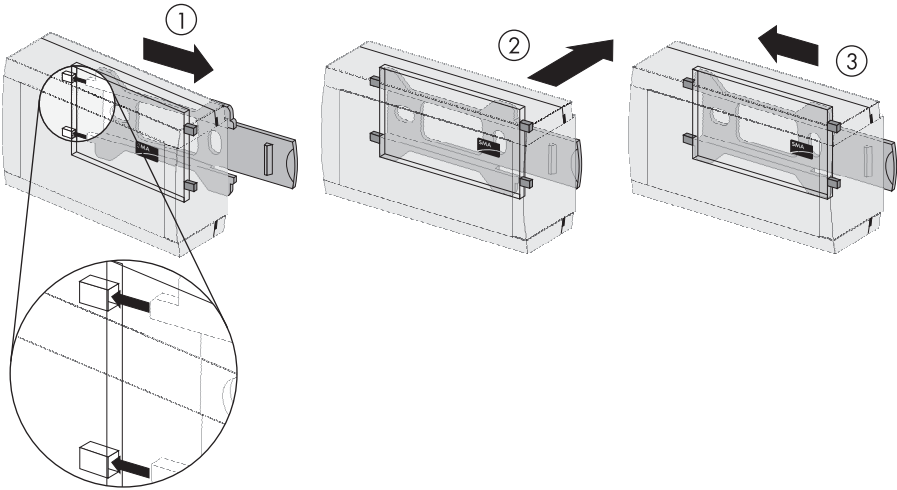

- The RS485 Power Injector is mounted on the wall.

6.4 SMA Power Injector with *Bluetooth*

6.4.1 Requirements for the mounting location

Observe the following requirements regarding the mounting location of the SMA Power Injector with *Bluetooth*:

- The SMA Power Injector with *Bluetooth* is intended for indoor installation only.
- The mounting location must be in the vicinity of a 100 V ... 240 V socket (plug-in power supply cable length 6 ft. (1,800 mm)).
- Protect the SMA Power Injector with *Bluetooth* from dust, moisture and corrosive substances.
- The ambient temperature must remain between $-13\text{ }^{\circ}\text{F}$ and $149\text{ }^{\circ}\text{F}$ ($-20\text{ }^{\circ}\text{C}$ and $+65\text{ }^{\circ}\text{C}$).
- The maximum cable length from the Sunny SensorBox to the SMA Power Injector with *Bluetooth* is 490 ft. (150 m).
- The maximum cable length for the alternate power supply device is 33 ft. (10 m).
- The wireless link at the mounting location must have a connection quality rating of "good" or higher (see section 6.4.3 "Determining the mounting/installation location" (page 36)).

- Certain ambient conditions can reduce the connection quality and data transmission speed between *Bluetooth* devices.
 - Mount or install the *Bluetooth* device at a distance of at least 3 ft. (1 m) from the following devices:
 - WLAN devices
 - Microwave ovens
 - Other devices that use the 2.4 GHz frequency band

6.4.2 Information on SMA Bluetooth

The SMA *Bluetooth* devices of your PV system can communicate and network with an SMA *Bluetooth* communication product via *Bluetooth* wireless technology. To ensure the devices communicate with each other and are interlinked, they have to be set to the same NetID. The NetID is the unique identification number of your PV system. It can therefore be used to distinguish your PV system from other SMA *Bluetooth* PV systems.



Determining the NetID for your PV system

If your *Bluetooth* PV system does not have a NetID yet, you first need to determine a free NetID with the Sunny Explorer or Sunny Beam with *Bluetooth* software applications and then set the devices of your PV system accordingly.

Extending the *Bluetooth* network with the SMA *Bluetooth* Repeater

The SMA *Bluetooth* Repeater can help you extend the wireless range of your *Bluetooth* network. When a SMA *Bluetooth* Repeater is set up at the coverage boundary of a *Bluetooth* network, it is capable of routing the data traffic in that network into its own wireless range. This technology allows you to set up *Bluetooth* networks that cover a much larger area than would be possible with just the Sunny SensorBox or SMA Power Injector with *Bluetooth*.

Further information about SMA *Bluetooth* Wireless Technology can be found in the download section at www.SMA-America.com.

6.4.3 Determining the mounting/installation location

Before mounting the SMA Power Injector with *Bluetooth*, you must first test the wireless connection between the device and your PV system at the specified mounting/installation location. The Sunny SensorBox does not have to be connected to the SMA Power Injector with *Bluetooth* in order to perform this test.

1. Turn the "MODE" rotary switch of the SMA Power Injector with *Bluetooth* to position "3". The sole purpose of this position is to determine the location of installation.

"MODE" ID	Meaning
0	normal operation
1	for servicing purposes only
2	for servicing purposes only
3	installation mode

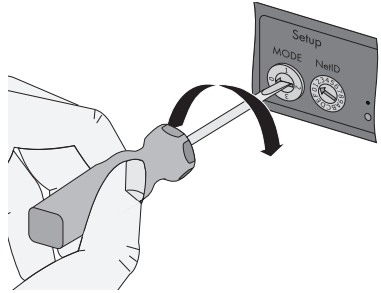

2. Turn the "NetID" rotary switch of the SMA Power Injector with *Bluetooth* to the NetID of your PV system. If your PV system does not have a NetID yet, see section 6.4.2 "Information on SMA Bluetooth" (page 35).

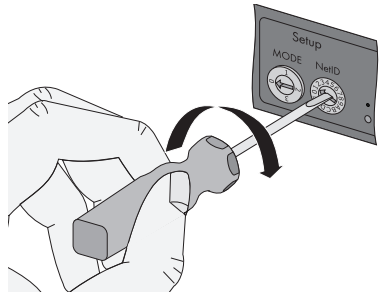

Layout of the switch positions	
NetID	Function
0	<i>Bluetooth</i> is switched off. The three yellow <i>Bluetooth</i> LEDs flash.
1 (Status upon delivery)	<i>Bluetooth</i> is switched on. The SMA Power Injector with <i>Bluetooth</i> can accept not more than two connections from a communication product such as a <i>Bluetooth</i> -enabled computer running Sunny Explorer or Sunny WebBox with <i>Bluetooth</i> . A connection to the Sunny Beam with <i>Bluetooth</i> is not possible. The three yellow <i>Bluetooth</i> LEDs flash.
2 - F	<i>Bluetooth</i> is switched on. The SMA Power Injector with <i>Bluetooth</i> can network with all SMA <i>Bluetooth</i> products that share the same NetID. A connection to the Sunny Beam with <i>Bluetooth</i> is not possible.

3. Connect the SMA Power Injector with *Bluetooth* to the power supply (see section 7.6.4 "Connecting the SMA Power Injector with Bluetooth to the power supply" (page 63)).
 - The SMA Power Injector with *Bluetooth* shows the connection quality to the next available SMA *Bluetooth* device. You can change the connection quality by moving the *Bluetooth* devices further apart or shifting their orientation. The connection quality must be rated as "good" or higher for the selected mounting/installation location (at least two yellow *Bluetooth* LEDs glow).
 - You must improve any connection that proves to be unreliable or too slow (see section 5.3.2 "LEDs indicating connection quality (Bluetooth LEDs)" (page 22)).
4. Disconnect the power and turn the rotary switch to "MODE 0".
 - The mounting/installation location for the SMA Power Injector with *Bluetooth* has been determined.

Once you have determined the best mounting location, you can mount the SMA Power Injector with *Bluetooth* on a wall or top hat rail.

6.4.4 Mounting the SMA Power Injector with *Bluetooth* on a wall

Included mounting accessories

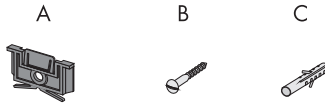

Position	Quantity	Designation
A	1	Bracket*
B	1	Screw
C	1	Wall anchor

* Can be found on the back of the SMA Power Injector with Bluetooth on delivery.

1. Remove the bracket from the back of the SMA Power Injector with *Bluetooth*.

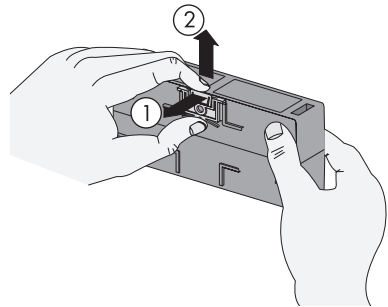

2. The mounting location must be determined based on the space available and the quality of the wireless connection to the *Bluetooth* network.
3. Label the drill hole.

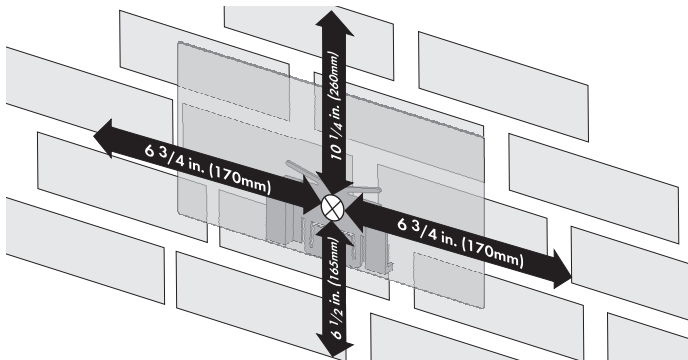

4. Drill a $\frac{1}{4}$ in. (6 mm) diameter hole at the designated point and insert a wall anchor.
5. Fasten the bracket to the wall with a screw.

- Slide the SMA Power Injector with *Bluetooth* into the bracket.

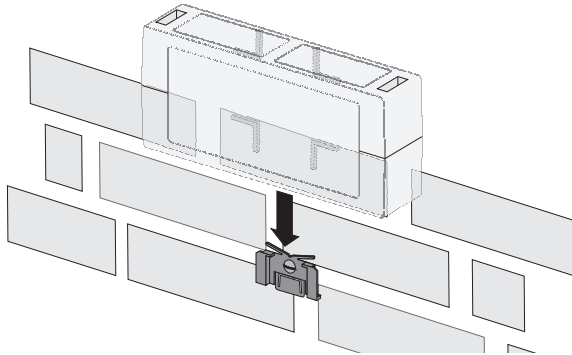

- The SMA Power Injector with *Bluetooth* is mounted.

Information on how to detach the SMA Power Injector with *Bluetooth* from the wall can be found in section 10.3 "Dismantling the SMA Power Injector with Bluetooth " (page 72).

6.4.5 Mounting the SMA Power Injector with *Bluetooth* on a top hat rail

Included mounting accessories



Position	Quantity	Designation
A	1	Bracket*

* Can be found on the back of the SMA Power Injector with Bluetooth on delivery.

- Remove the bracket from the back of the SMA Power Injector with *Bluetooth*.

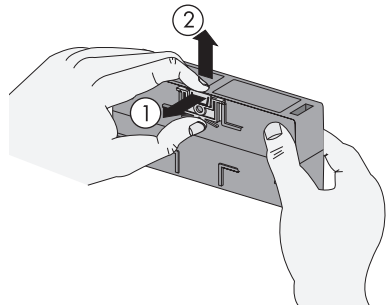

2. Hook the ridge at the top of the SMA Power Injector with *Bluetooth* into the top edge of the top hat rail.
3. Press the SMA Power Injector with *Bluetooth* down on the top hat rail and hold.
4. Press the middle of the bracket down into the guide rail until it snaps into place.

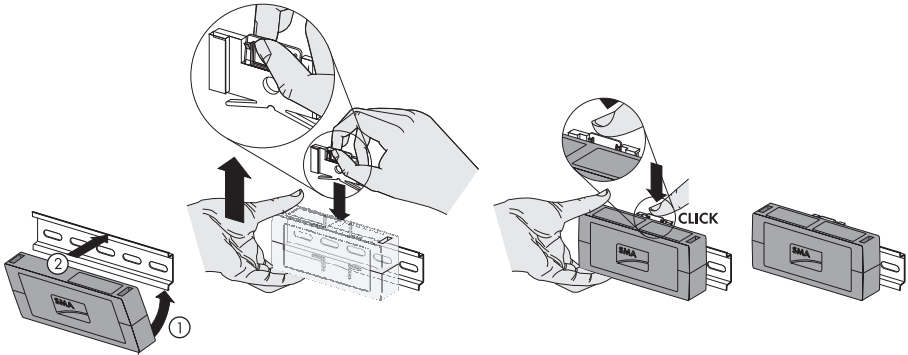
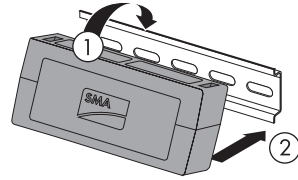

- The SMA *Bluetooth* Repeater is mounted.

Information on how to detach the SMA Power Injector with *Bluetooth* from the top-hat rail can be found in section 10.3 "Dismantling the SMA Power Injector with *Bluetooth* " (page 72).

7 Startup

7.1 Information on starting up the device

This section shows you how to connect external sensors and start up the Sunny SensorBox with the RS485 Power Injector or the SMA Power Injector with *Bluetooth*.

For initial startup, the following steps must be taken:

- Connect the module temperature sensor (see page 41).
- If necessary, connect the anemometer (see page 43).
- If necessary, connect the ambient temperature sensor (see page 44).
- Connect the Sunny SensorBox to the RS485 communication bus via the RS485 Power Injector and turn it on (see page 45) or connect the Sunny SensorBox to the SMA Power Injector with *Bluetooth* and turn it on (see page 58).

NOTICE

Ingress of water.

Damage to the Sunny SensorBox will result.

- Ensure the gasket is properly seated in the cable gland.

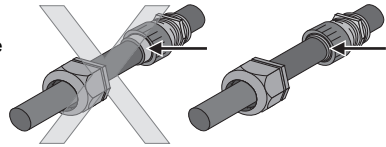

7.2 Connecting the module temperature sensor



Cable length with a 2-conductor technology

The connection is made via a 8 ft. (2.5 m) cable. The cable must not be extended or cut. The measurement accuracy depends on the cable length.

1. Open the Sunny SensorBox (see page 66).
2. Unscrew the lock nut of the cable gland on the bottom left of the Sunny SensorBox and remove the filler plugs.
3. Thread the sensor cable through the lock nut and the cable gland at the bottom left and into the enclosure of the Sunny SensorBox and tighten the cable gland.

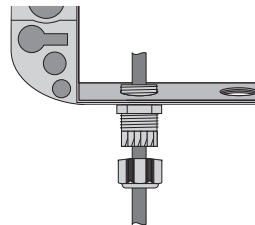

- 4. Connect the sensor on the "F7: TmpMdul" terminal of the Sunny SensorBox. The polarity of the cables is arbitrary.

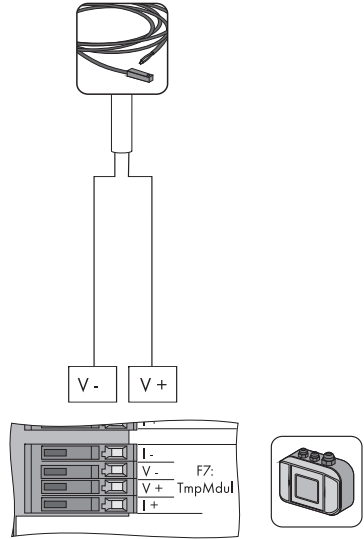

- 5. Make sure the gasket of the cable gland is properly seated.
- 6. Screw the lock nut onto the cable gland with a torque of 7 in-lbs. (0.8 Nm) to fix the cable.
- 7. Securely lay the cable using suitable fastening material.
- The module temperature sensor is connected.

You can now connect additional sensors or connect the Sunny SensorBox via the RS485 Power Injector or the SMA Power Injector with *Bluetooth* and turn it on.

7.3 Connecting the anemometer



Specified cable length when connecting to the SensorBox

- Note the cable length specified in the sensor manual.

- Open the Sunny SensorBox (see page 66).
- Unscrew the lock nut of the cable gland on the top left of the Sunny SensorBox and remove the filler plugs.
- Thread the sensor cable through the lock nut and the cable gland at the top left and into the enclosure of the Sunny SensorBox and tighten the cable gland.

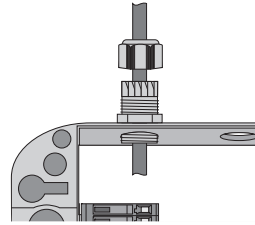

- Connect the sensor on the "F3: Wind" terminal of the Sunny SensorBox. The polarity of the cables is arbitrary.



IP + IP -

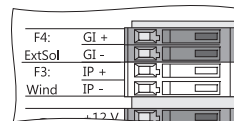

- Make sure the gasket of the cable gland is properly seated.
- Screw the lock nut onto the cable gland with a torque of 7 in-lbs. (0.8 Nm).
- Lay the cable using suitable fastening material.
- The anemometer is connected.

You can now connect additional sensors or connect the Sunny SensorBox via the RS485 Power Injector or the SMA Power Injector with *Bluetooth* and turn it on.

7.4 Connecting the ambient temperature sensor



Specified cable length when connecting to the SensorBox

- Observe the cable length specified in the sensor manual.

1. Open the Sunny SensorBox (see page 66).
2. Unscrew the lock nut of the cable gland on the bottom center of the Sunny SensorBox and remove the filler plugs.
3. Thread the sensor cable through the lock nut and the cable gland to the bottom center and tighten the cable gland.
4. Remove the termination resistor and the bridge from the "F6: TmpAmp" terminal of the Sunny SensorBox.
5. Connect the sensor to the "F6: TmpAmb" terminal of the Sunny SensorBox.

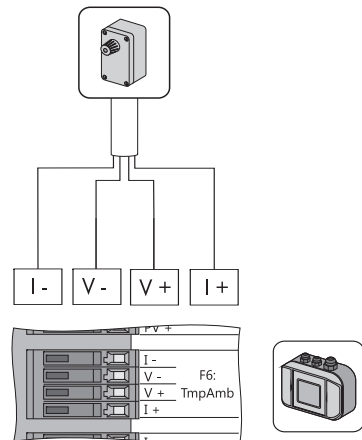
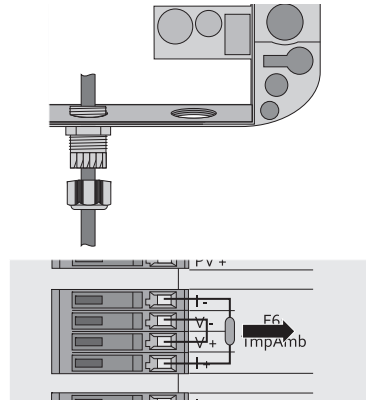

6. Make sure the gasket of the cable gland is properly seated.
 7. Screw the lock nut onto the cable gland with a torque of 7 in-lbs. (0.8 Nm).
 8. Lay the cable using suitable fastening material.
- The ambient temperature sensor is connected.

You can now connect additional sensors or connect the Sunny SensorBox via the RS485 Power Injector or the SMA Power Injector with *Bluetooth* and turn it on.

7.5 Startup via the RS485-Power Injector

7.5.1 Information on starting up the device

The RS485 Power Injector is used to integrate the Sunny SensorBox into the RS485 communication bus. The RS485 Power Injector is designed to supply the Sunny SensorBox with power. It is recommended to place the Sunny SensorBox at the end of the RS485 communication bus. The required termination has already been pre-wired.



Information on RS485 cabling

See the RS485 cabling plan poster for information on RS485 cabling.

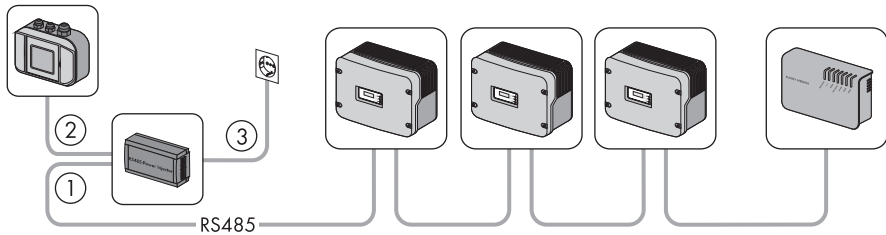

To connect the Sunny SensorBox to the RS485 communication bus, proceed as follows:

- ① Connect the RS485 Power Injector to a RS485 bus node (see page 46).
- ② Connect the RS485 Power Injector to the Sunny SensorBox (see page 48).
- ③ Connect the RS485 Power Injector to the power supply (see page 57).

The following options are also available:

- Connect the Sunny SensorBox to another Sunny SensorBox (see page 51)
- Connect the Sunny SensorBox to another RS485 bus node (see page 55)

7.5.2 Connecting the RS485-Power Injector to a RS485 bus node

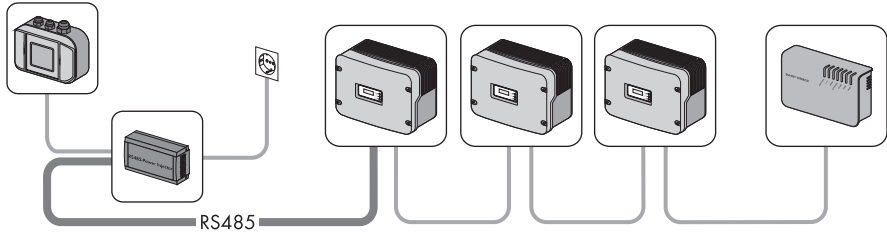

RS485 bus node

1. Connect the cables to the RS485 bus nodes as described in the RS485 bus node manual.

RS485 Power Injector

2. Remove about $1\frac{5}{8}$ in. (40 mm) of cable sleeve from the RS485 Power Injector end of the RS485 communication cable.
3. Shorten the cable shield by $\frac{5}{8}$ in. (1.5 cm).
4. Pull back the cable shield and cover with conductive adhesive film. This is where the shield clamp will be attached later.
5. Shorten unused wires until flush with the cable sleeve.
6. Strip $\frac{1}{4}$ in. (6 mm) of insulation from the wires.

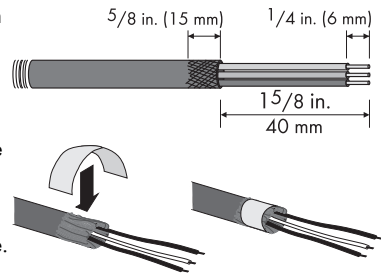

Connection layout and system wiring

See the RS485 cabling plan for the connection layout and system wiring.

- 7. Connect the wires to the plug. Note the configurations of your RS485 communication bus. If necessary, write down the color of the wires.

2 | D+ _____
5 | GND _____
7 | D- _____

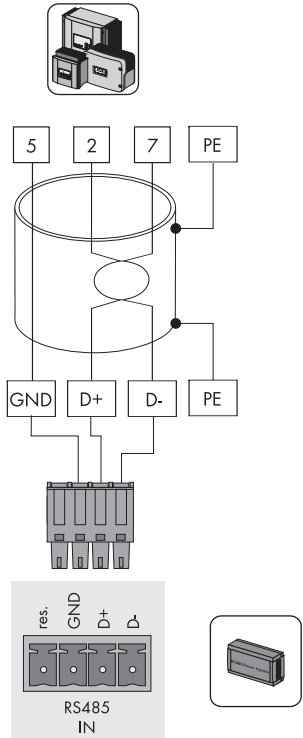

- 8. Insert the plug into the "RS485 IN" socket of the RS485 Power Injector.

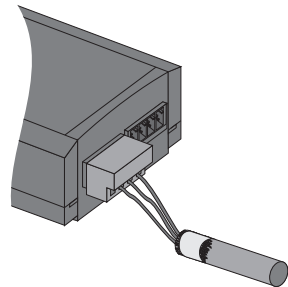

- The RS485 Power Injector is connected to the RS485 communication bus.

You can now connect the RS485 Power Injector to the Sunny SensorBox.

7.5.3 Connecting the RS485 Power Injector to the Sunny SensorBox

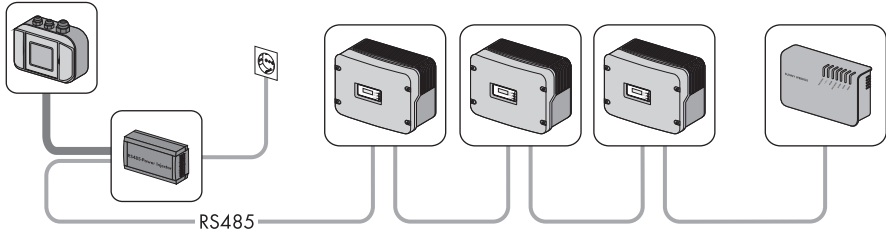

NOTICE

Short circuit due to faulty wiring.

- The RS485 Power Injector must be connected directly to the Sunny SensorBox.
- Do not connect any other RS485 bus node between these two devices.

RS485 Power Injector

1. Remove about 1 5/8 in. (40 mm) of cable sleeve from the RS485 Power Injector end of the RS485 communication cable.
2. Shorten the cable shield by 5/8 in. (1.5 cm).
3. Pull back the cable shield and cover with conductive adhesive film. This is where the shield clamp will be attached later.
4. Shorten unused wires until flush with the cable sleeve.
5. Strip 1/4 in. (6 mm) of insulation from the wires.
6. Connect the wires with the plug.

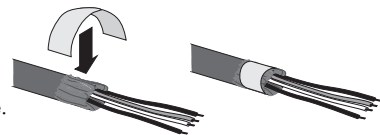
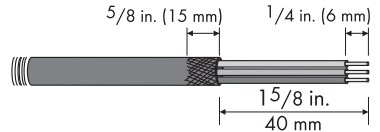

Write down the color of the wires:

- +12V _____
- GND _____
- D+ _____
- D- _____

7. Insert the plug into the "RS485+Power OUT" socket of the RS485 Power Injector.

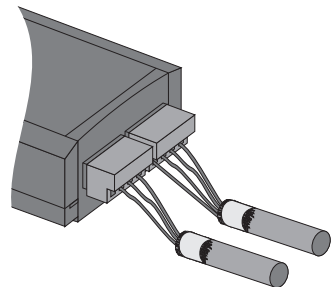

- The RS485 Power Injector is connected.

- Attach the shield clamp.

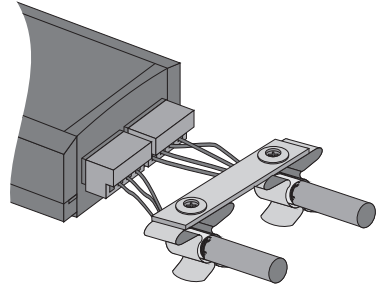

- Route the RS485 communication cable from the RS485 Power Injector to the Sunny SensorBox.

Sunny SensorBox

- Open the Sunny SensorBox (see page 66).
- Unscrew the lock nut of the cable gland on the bottom right of the Sunny SensorBox and remove the filler plugs.
- Thread the RS485 communication cable through the lock nut and the cable gland and into the enclosure of the Sunny SensorBox.

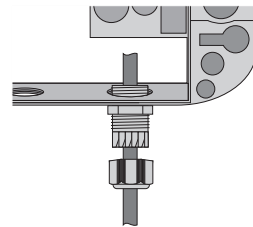

NOTICE

Metal or cable scraps could fall into the open device while working on the device. Damage to the Sunny SensorBox will result.

- Remove all metal scraps from the cable shield or cable from inside the Sunny SensorBox before closing the device.

- Remove 1⁵/₈ in. (40 mm) of cable sleeve from the RS485 communication cable that is connected to the Sunny SensorBox.
- Strip 1/4 in. (6 mm) of insulation from the wires.
- Twist the cable shield into one string. The cable shield is only needed if another Sunny SensorBox is connected.
- Pull the insulating tube over the cable shield. Allow 1⁵/₈ in. (40 mm) of the cable shield to stick out of the insulating tube.

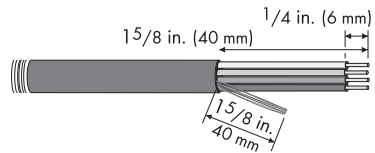

17. Insert the detached cable shield into the terminal.

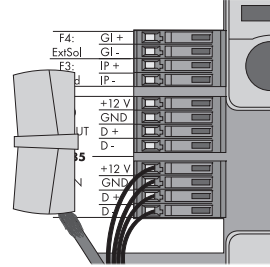

18. Connect the wires to the "RS485 F1: IN" terminal of the Sunny SensorBox. Observe the noted wire colors.

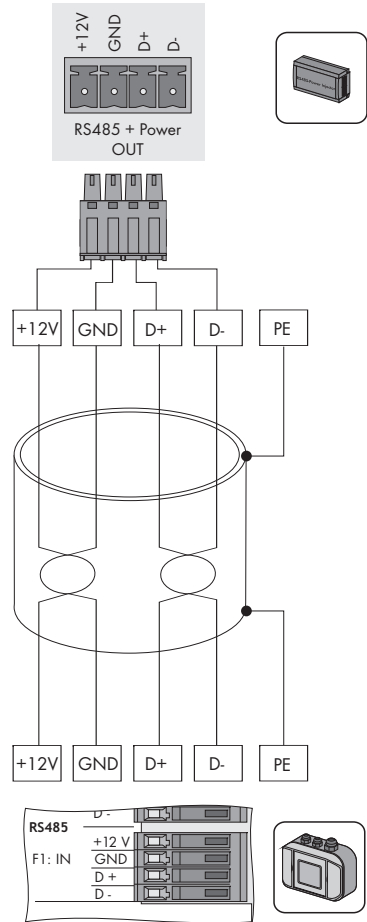

19. Make sure the gasket of the cable gland is properly seated.

20. Screw the lock nut onto the cable gland with a torque of 7 in-lbs. (0.8 Nm).

21. If necessary, connect another Sunny SensorBox or RS485 bus node (see pages 51 or 55).
 22. Check the RS485 cabling plan poster to find out whether the terminating resistor has to be plugged into the "RS485 F2: OUT" terminal.
 23. Close the Sunny SensorBox (see page 66).
- The RS485 Power Injector is connected to the Sunny SensorBox.

7.5.4 Connecting the Sunny SensorBox to another Sunny SensorBox

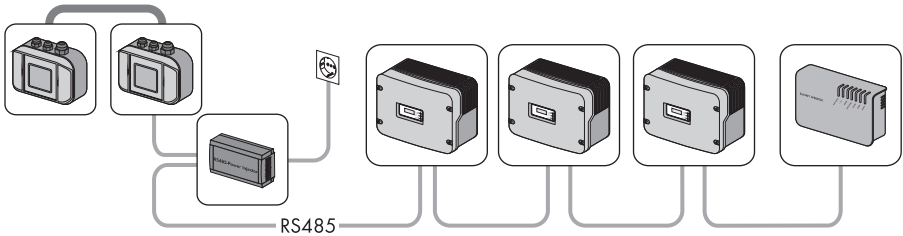

You can add an additional Sunny SensorBox to the Sunny SensorBox. If you add another Sunny SensorBox, note that you can use the RS485 Power Injector to supply power to up to five Sunny SensorBoxes in total.

Connection to an installed Sunny SensorBox

NOTICE

Metal or cable scraps could fall into the open device while working on the device. Damage to the Sunny SensorBox will result.

- Remove all metal scraps from the cable shield or cable from inside the Sunny SensorBox before closing the device.

1. Open the Sunny SensorBox (see page 66).
2. Remove the termination resistor for "F2: OUT RS485" on the installed Sunny SensorBox.

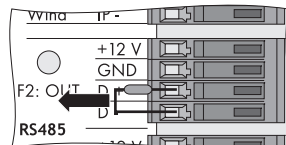

3. Unscrew the lock nut of the cable gland at the top right of the installed Sunny SensorBox and remove the filler plugs.
4. Thread the RS485 communication cable through the lock nut and the cable gland into the enclosure of the installed Sunny SensorBox.

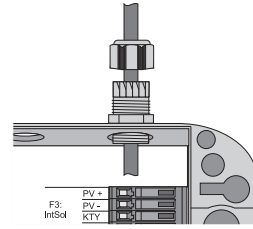

5. Remove 1 5/8 in. (40 mm) of cable sleeve from the RS485 communication cable that is connected to the installed Sunny SensorBox.
6. Strip 1/4 in. (6 mm) of insulation from the wires.
7. Twist the cable shield into one string.
8. Pull the insulating tube over the cable shield. Allow 1 5/8 in. (40 mm) of the cable shield to stick out of the insulating tube.
9. Insert the detached cable shield into the terminal.
10. Connect the wires to the "F2: OUT RS485" terminals of the installed Sunny SensorBox.

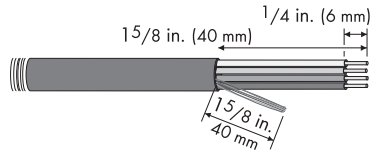

Write down the color of the wires:

- +12V _____
- GND _____
- D+ _____
- D- _____

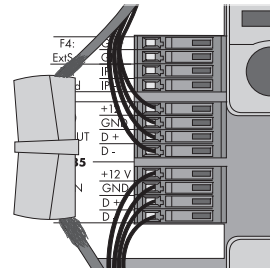

11. Make sure the gasket of the cable gland is properly seated.
12. Screw the lock nut onto the cable gland with a torque of 7 in-lbs. (0.8 Nm) to fix the RS485 communication cable.
13. Close the installed Sunny SensorBox (see page 66).
 - The RS485 communication cable is now connected to the installed Sunny SensorBox.

Connection to another Sunny SensorBox

14. Mount the Sunny SensorBox you want to connect as described in section 6 "Mounting the device" (page 24).
15. Open the Sunny SensorBox (see page 66).
16. Unscrew the lock nut of the cable gland on bottom right of the Sunny SensorBox you want to connect and remove the filler plugs.

17. Thread the RS485 communication cable through the lock nut and the cable gland into the enclosure of the Sunny SensorBox.

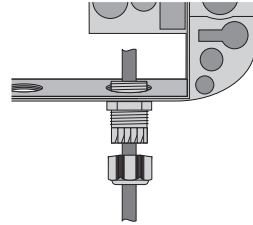

18. Remove $1\frac{5}{8}$ in. (40 mm) of cable sleeve from the RS485 communication cable that is connected to the Sunny SensorBox.
19. Strip $\frac{1}{4}$ in. (6 mm) of insulation from the wires.
20. Twist the cable shield into one string. The cable shield is only needed if another Sunny SensorBox is connected.
21. Pull the insulating tube over the cable shield. Allow $1\frac{5}{8}$ in. (40 mm) of the cable shield to stick out of the insulating tube.
22. Insert the detached cable shield into the terminal.

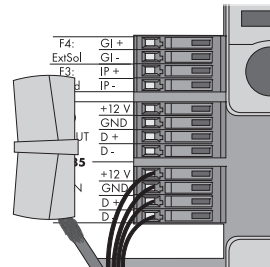
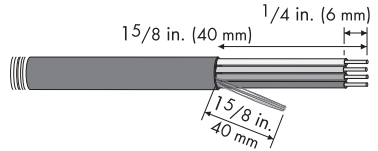

23. Connect the RS485 communication cable to the "F1: IN RS485" terminals of the Sunny SensorBox. Observe the noted wire colors.

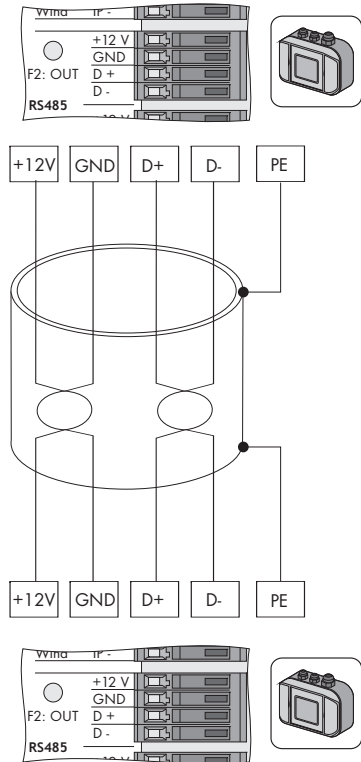

24. Make sure the gasket of the cable gland is properly seated.
25. Screw the lock nut onto the cable gland with a torque of 7 in-lbs. (0.8 Nm) to fix the RS485 communication cable.
26. If necessary, connect another Sunny SensorBox or RS485 bus node (see pages 51 or 55).
27. Make sure the termination resistor is plugged in (see section 9.2 "Terminating the RS485 bus on the Sunny SensorBox" (page 67)).
28. Close the Sunny SensorBox (see page 66).
- The additional Sunny SensorBox is now connected.

7.5.5 Connecting the Sunny SensorBox to an additional RS485 bus node

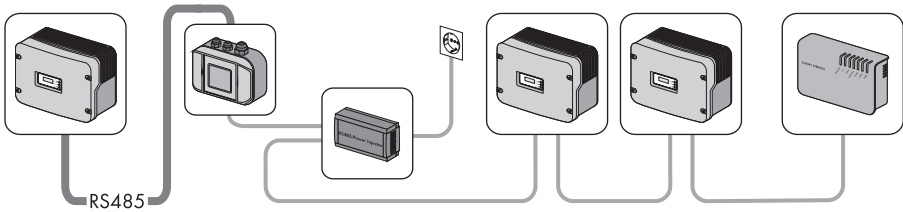

1. Open the Sunny SensorBox (see page 66).
2. Remove the termination resistor at "F2: OUT RS485" on the Sunny SensorBox.
3. Unscrew the lock nut of the cable gland at the top right of the Sunny SensorBox and remove the filler plugs.
4. Thread the RS485 communication cable through the lock nut and the cable gland and into the enclosure of the Sunny SensorBox.

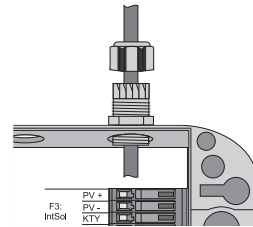
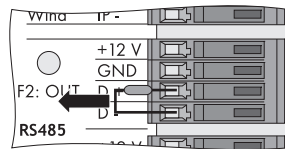

NOTICE

Metal or cable scraps could fall into the open device while working on the device. Damage to the Sunny SensorBox will result.

- Remove all metal scraps from the cable shield or cable from inside the Sunny SensorBox before closing the device.

5. Remove 1 5/8 in. (40 mm) of cable sleeve from the RS485 communication cable that is connected to the Sunny SensorBox.
6. Strip 1/4 in. (6 mm) of insulation from the wires.
7. Twist the cable shield into one string.

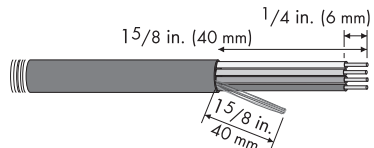

8. Pull the insulating tube over the cable shield. Allow 1 5/8 in. (40 mm) of the cable shield to stick out of the insulating tube.

- 9. Insert the detached cable shield into the terminal.

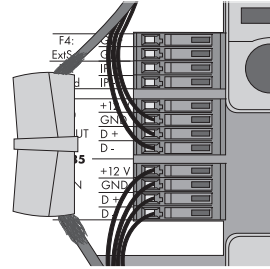

- 10. Connect the wires to the "F2: OUT RS485" terminals of the Sunny SensorBox. Note the configurations in your RS485 communication bus.

Write down the color of the wires:

GND | 5 _____
 D+ | 2 _____
 D- | 7 _____

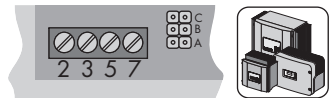
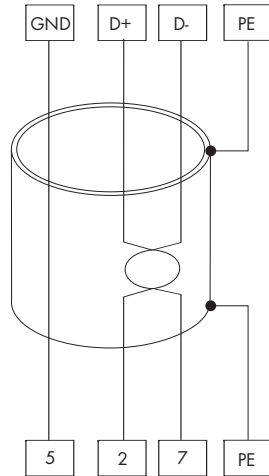
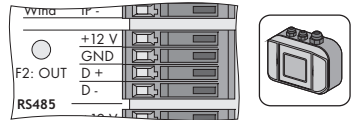

- 11. Make sure the gasket of the cable gland is properly seated.
- 12. Screw the lock nut onto the cable gland with a torque of 7 in-lbs. (0.8 Nm) to fix the RS485 communication cable.
- 13. Make sure the termination resistor is plugged in (see section 9.2 "Terminating the RS485 bus on the Sunny SensorBox" (page 67)).
- 14. Close the Sunny SensorBox (see page 66).
- The SensorBox is connected to another RS485 bus node.

7.5.6 Connecting the RS485 Power Injector to the power supply

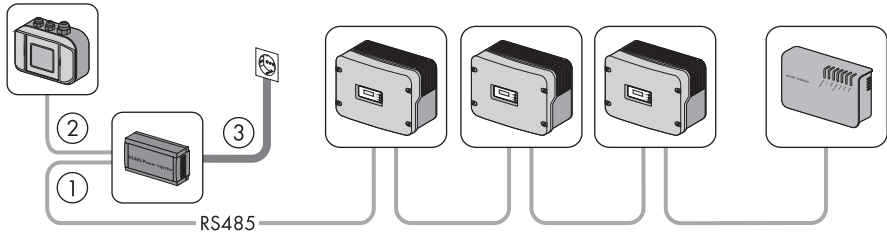

Before you connect the RS485 Power Injector to the power supply, make sure all the devices are properly connected and the inverter and communication devices have been switched on.

1. Connect the DC plug of the plug-in power supply unit into the DC terminal of the RS485 Power Injector.
2. Insert the plug-in power supply unit into a power outlet.
- It takes about one minute for the Sunny SensorBox to start up once it has been connected to the power supply. The "Power" LED on the RS485 Power Injector lights up.
 - If the "Power" LED on the RS485 Power Injector does not light up, refer to section 11 "Troubleshooting" (page 74).

The startup procedure of the Sunny SensorBox is complete. You can now detect the Sunny SensorBox with a communication product such as the Sunny WebBox and view the data collected by the sensors.

7.6 Startup via the SMA Power Injector with *Bluetooth*

7.6.1 Information on starting up the device

The Sunny SensorBox is integrated into the SMA *Bluetooth* network via the SMA Power Injector with *Bluetooth*. The SMA Power Injector with *Bluetooth* is designed to supply power to one Sunny SensorBox only.

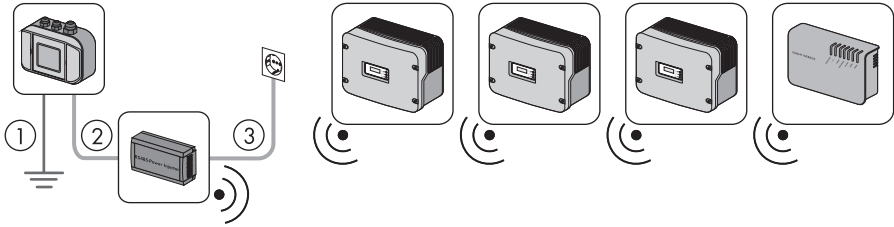

To connect the Sunny SensorBox to the SMA Power Injector with *Bluetooth*, proceed as follows:

- ① Ground the Sunny SensorBox (see page 58).
- ② Connect the SMA Power Injector with *Bluetooth* to the Sunny SensorBox (see page 60).
- ③ Connect the SMA Power Injector with *Bluetooth* to the power supply (see page 63).

7.6.2 Grounding the Sunny SensorBox

Sunny SensorBox

1. Open the Sunny SensorBox (see page 66).
2. Unscrew the lock nut of the cable gland at the bottom center of the Sunny SensorBox and remove the filler plugs.
3. Thread the ground cable through the lock nut and the cable gland into the Sunny SensorBox enclosure.

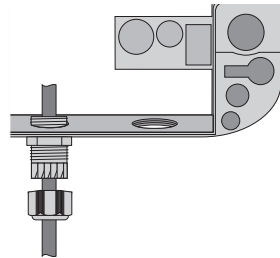

4. Plug the ground cable into the terminal.

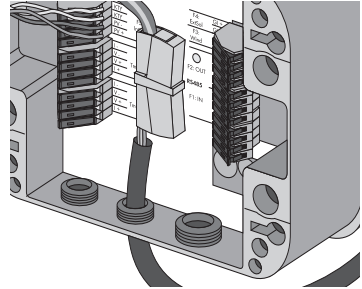

5. Make sure the gasket of the cable gland is properly seated.
6. Screw the lock nut onto the cable gland with a torque of 7 in-lbs. (0.8 Nm) to fix the ground cable.

Mounting Plate or roof bracket

7. Screw the cable lug with ground cable onto the mounting plate or roof bracket.

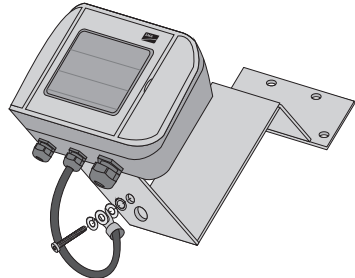
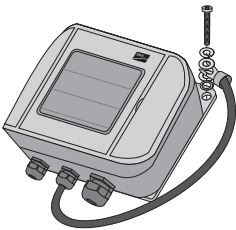

- The Sunny SensorBox is grounded.

You can connect the Sunny SensorBox to the SMA Power Injector with *Bluetooth*.

7.6.3 Connecting the Sunny SensorBox to the SMA Power Injector with Bluetooth

NOTICE

Damage to the SMA Power Injector with Bluetooth or the bracket.

The SMA Power Injector with *Bluetooth* could loosen itself and fall off the bracket.

- Be sure to hold the SMA Power Injector with *Bluetooth* firmly in place when removing or inserting cables.

SMA Power Injector with Bluetooth

1. Remove $1\frac{5}{8}$ in. (40 mm) of cable sheath from the RS485 communication cable that is connected to the SMA Power Injector with *Bluetooth*.
2. Strip $\frac{1}{4}$ in. (6 mm) of insulation from four wires.
3. Shorten the unused wires and the cable shield until flush with the cable sleeve.
4. Connect the wires with the plug.

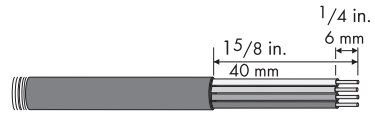

Write down the color of the wires:

+12V _____

GND _____

D+ _____

D- _____

5. Insert the plug into the "DEVICE" socket of the SMA Power Injector with *Bluetooth*.



If not connected properly, the SMA Power Injector with Bluetooth will not work correctly.

- Connect only one Sunny SensorBox to the socket "DEVICE".
 - Do not connect any other devices to the socket "DEVICE".
6. Route the RS485 communication cable from the SMA Power Injector with *Bluetooth* to the Sunny SensorBox.

Sunny SensorBox

7. Open the Sunny SensorBox (see page 66).
8. Unscrew the lock nut of the cable gland on the bottom right of the Sunny SensorBox and remove the filler plugs.

- Thread the RS485 communication cable through the lock nut and the cable gland into the enclosure of the Sunny SensorBox.

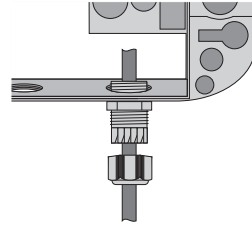

NOTICE

Metal or cable scraps could fall into the open device while working on the device. Damage to the Sunny SensorBox will result.

- Remove all metal scraps from the cable shield or cable from inside the Sunny SensorBox before closing the device.

- Remove 1⁵/₈ in. (40 mm) of cable sleeve from the RS485 communication cable that is connected to the Sunny SensorBox.

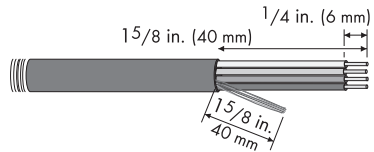

- Strip 1/4 in. (6 mm) of insulation from the wires.
- Twist the cable shield into one string.
- Pull the insulating tube over the cable shield. Allow 1⁵/₈ in. (40 mm) of the cable shield to stick out of the insulating tube.
- Insert the detached cable shield together with the ground cable of the Sunny SensorBox into the terminal.

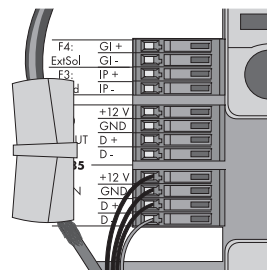

- 15. Connect the wires to the "RS485 F1: IN" terminal of the Sunny SensorBox. Observe the noted wire colors.

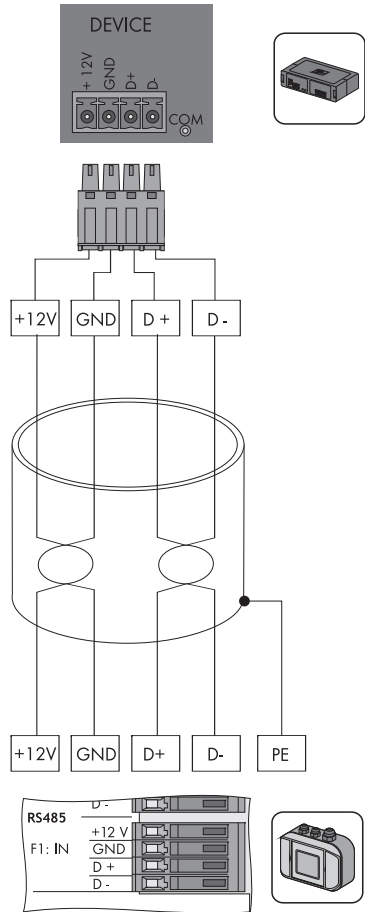

- 16. Make sure the termination resistor is plugged into the "RS485 F2: OUT" terminal. The termination resistor must be plugged in.

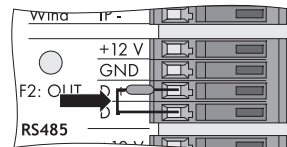

- 17. Make sure the gasket of the cable gland is properly seated.
- 18. Screw the lock nut onto the cable gland with a torque of 7 in-lbs. (0.8 Nm).
- The SMA Power Injector with *Bluetooth* is connected to the Sunny SensorBox. You can now use the SMA Power Injector with *Bluetooth* to supply power to the Sunny SensorBox.

7.6.4 Connecting the SMA Power Injector with Bluetooth to the power supply

Requirements

- The NetID of your PV system is set on the SMA Power Injector with *Bluetooth* (see section 6.4.3 "Determining the mounting/installation location" (page 36)).
- "MODE 0" is set on the SMA Power Injector with *Bluetooth* (see section 6.4.3 "Determining the mounting/installation location" (page 36)).
- All devices are connected.
- The inverter and the communication devices have all been switched on.

Procedure

Power can be supplied in three different ways:

- The plug-in power supply unit included in the delivery.
- Alternate power sources (AC or DC).

Power from the Plug-in power supply unit

1. Connect the DC plug of the plug-in power supply unit to the DC terminal of the SMA Power Injector with *Bluetooth*.
 2. Attach the relevant country adapter to the plug-in power supply unit.
 3. Insert the plug-in power supply unit into a power outlet.
- The SMA Power Injector with *Bluetooth* is connected to the power supply. The "RDY" LED glows green continuously. It takes about one to two minutes for the Sunny SensorBox to start up once it is connected to the power supply. The blue *Bluetooth* LED on the SMA Power Injector with *Bluetooth* glows continuously. Following initial startup, it can take three to four minutes before the Sunny SensorBox is ready for use.
- If the "RDY" LED on the SMA Power Injector with *Bluetooth* does not light up, refer to section 11 "Troubleshooting" (page 74).
 - If the blue *Bluetooth* LED on the SMA Power Injector with *Bluetooth* does not glow continuously, refer to section 11 "Troubleshooting" (page 74).

The startup procedure of the Sunny SensorBox is complete. You can now detect the Sunny SensorBox with a communication product (e.g., the Sunny WebBox with *Bluetooth* or Sunny Explorer) and view the data collected by the sensors.

Power from the power module

 DANGER
<p>High voltages are present in the Sunny Boy during operation.</p> <p>Death or serious injury due to electric shock.</p> <ul style="list-style-type: none"> • All work on the Sunny Boy must only be carried out by qualified personnel.

You can use the power module from SMA as an alternate power source for the SMA Power Injector with *Bluetooth*.

To do so, proceed as follows:

1. Install the power module into the inverter as described in the power module installation guide.
 2. Connect the plug of the SMA Power Injector with *Bluetooth* to the pre-assembled power cable of the power module.
 3. Insert the plug into the connection terminal of the alternate power supply for the SMA Power Injector with *Bluetooth*.
- The SMA Power Injector with *Bluetooth* is connected to the power supply. The "RDY" LED glows green continuously. It takes about one to two minutes for the Sunny SensorBox to start up once it is connected to the power supply. The blue *Bluetooth* LED on the SMA Power Injector with *Bluetooth* glows continuously. Following initial startup, it can take three to four minutes before the Sunny SensorBox is ready for use.
- If the "RDY" LED on the SMA Power Injector with *Bluetooth* does not light up or flash, refer to section 11 "Troubleshooting" (page 74).
 - If the blue *Bluetooth* LED on the SMA Power Injector with *Bluetooth* does not glow continuously, refer to section 11 "Troubleshooting" (page 74).

The startup procedure of the Sunny SensorBox is complete. You can now detect the Sunny SensorBox with a communication product (e.g., the Sunny WebBox with *Bluetooth* or Sunny Explorer) and view the data collected by the sensors.

Power from alternate sources

NOTICE

Overvoltage due to unsuitable power source.

Damage to the SMA Power Injector with *Bluetooth*.

- Only use the plug-in power supply that comes with the SMA Power Injector with *Bluetooth* or the power module from SMA.
- Observe the requirements of the alternate power source.

You can use an alternate power source to supply the SMA Power Injector with *Bluetooth* with power. Observe the following requirements for the power source:

DC Source Requirements

- Output voltage: normally 12 V ... 24 V DC \pm 20 %
- Output power: minimum 2 W
- Cable cross-section: > AWG 28 (0.1 mm²)
- Maximum cable length: 33 ft. (10 m)

AC Source Requirements

- Output voltage U_{eff} : 12 V ... 24 V AC eff \pm 10 %
- Output power: min. 2 W (plug-in power supply: min. 2.5 W)
- Cable cross-section: > AWG 28 (0.1 mm²)
- Maximum cable length: 33 ft. (10 m)

To connect the SMA Power Injector with *Bluetooth* to an alternate power source, proceed as follows:

1. Connect the cable of the alternate power source to the plug connector included in the delivery.
 2. Insert the plug into the connection terminal of the alternate power supply for the SMA Power Injector with *Bluetooth*.
- The SMA Power Injector with *Bluetooth* is connected to the power supply. The "RDY" LED glows green continuously. It takes about one to two minutes for the Sunny SensorBox to start up once it is connected to the power supply. The blue *Bluetooth* LED on the SMA Power Injector with *Bluetooth* glows continuously. Following initial startup, it can take three to four minutes before the Sunny SensorBox is ready for use.
- If the "RDY" LED on the SMA Power Injector with *Bluetooth* does not light up or flash, refer to section 11 "Troubleshooting" (page 74).
 - If the blue *Bluetooth* LED on the SMA Power Injector with *Bluetooth* does not glow continuously, refer to section 11 "Troubleshooting" (page 74).

The startup procedure of the Sunny SensorBox is complete. You can now detect the Sunny SensorBox with a communication product (e.g., the Sunny WebBox with *Bluetooth* or Sunny Explorer) and view the data collected by the sensors.

8 Opening and closing the Sunny SensorBox

8.1 Opening the Sunny SensorBox

1. Using the notches as a guide, open the side flaps of the Sunny SensorBox.
 2. Loosen the screws in the corners of the Sunny SensorBox.
 3. Open the enclosure lid up towards the left. The lid is connected to the lower shell by hooks.
- The Sunny SensorBox is open.

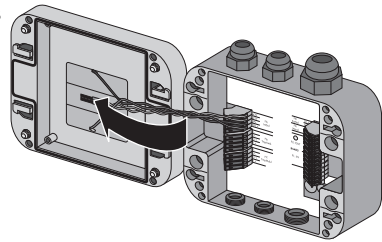
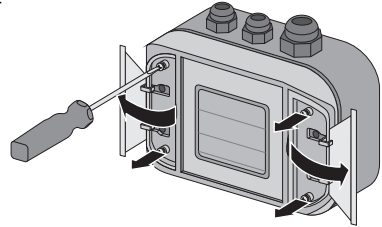

8.2 Closing the Sunny SensorBox

1. Check the sealing of the Sunny SensorBox enclosure before closing the lid on the lower enclosure shell. If the sealing of the enclosure has become porous over time, make sure you replace the enclosure gaskets (see section 9.4 "Replacing the gaskets of the Sunny SensorBox" (page 68)).
 2. Close the lid of the Sunny SensorBox on the lower enclosure shell.
 3. Initially turn the screws of the enclosure lid a little to the left, until the screws fall into the first turn of the thread.
 4. Insert screws into the lower enclosure shell and tighten with a torque of 9 in-lbs. (1 Nm).
 5. Close the side flaps of the Sunny SensorBox.
- The Sunny SensorBox is closed.

9 Maintenance and care

9.1 Maintenance

Inspect the Sunny SensorBox and the RS485 Power Injector or SMA Power Injector with *Bluetooth* for signs of external damage or dirt on a regular basis.

If the integrated PV cell of the Sunny SensorBox or the sensors are dirty (e.g., from leaves or bird droppings), the data they provide will be incorrect. Clean the Sunny SensorBox and sensors at regular intervals. Information on how to clean the Sunny SensorBox is provided in section 9.5 "Care" (page 70).

If a component becomes defective or no longer complies with safety standards, then replace the device, the sensors or the cable.

9.2 Terminating the RS485 bus on the Sunny SensorBox



Termination of the RS485 communication bus

Refer to the RS485 cabling plan poster for the termination of an RS485 communication bus.

Termination is carried out by means of a termination resistor. The termination resistor is already installed upon delivery.

1. Connect the termination resistor on the "RS485 F2: OUT" terminal to the "D+" and "D-" terminals.
- The Sunny SensorBox is terminated.

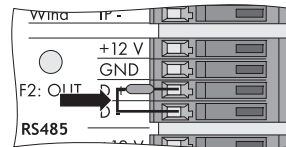

9.3 Connecting the integrated solar radiation sensor

The integrated solar radiation sensor in the lid of the Sunny SensorBox is already connected upon delivery. You can reconnect the integrated solar radiation sensor if you previously disabled it.

To connect the sensor, proceed as follows:

1. Remove the plug-in power supply unit of the RS485 Power Injector from the power outlet.
 2. Open the Sunny SensorBox (see page 66).
 3. Connect the sensor on the "F5: IntSol" terminal of the Sunny SensorBox.
 KTY yellow cable
 KTY yellow cable
 PV - blue cable
 PV+ red cable
 4. Close the Sunny SensorBox (see page 66).
- The integrated solar radiation sensor is now connected to the Sunny SensorBox.

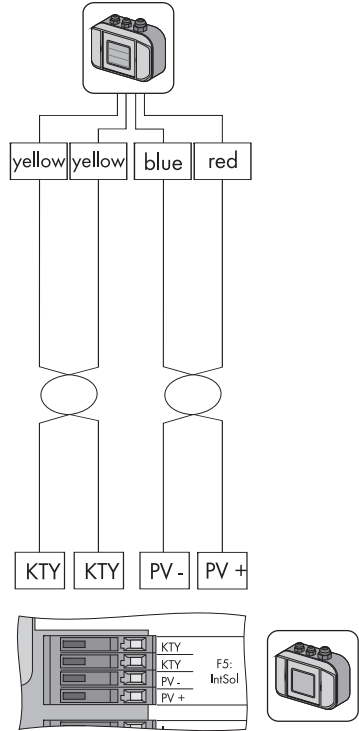

9.4 Replacing the gaskets of the Sunny SensorBox

The enclosure sealing and the gaskets of the cable glands in the Sunny SensorBox will become porous over time. If, after a lengthy period of operation, you open and close the Sunny SensorBox or make adjustments to the cable glands, then the gaskets and seals will no longer serve their intended purpose.

Replace the gaskets if you open the Sunny SensorBox (e.g., for retrofitting needs) for the first time in five years of operation. Be sure to order a new gasket set for the Sunny SensorBox before beginning any maintenance work.

To replace the gaskets of the Sunny SensorBox, proceed as follows:

1. Open the Sunny SensorBox (see page 66).
2. Remove the relevant cable from the cable gland in the reverse order in which it is connected.

3. Unscrew the old cable gland from the Sunny SensorBox.

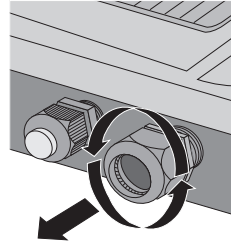

4. Place the appropriate gasket ring onto the thread of the new cable gland.

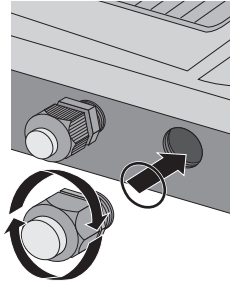

NOTICE

Ingress of water.

Damage to the Sunny SensorBox will result.

- Ensure the gasket is properly seated in the cable gland.

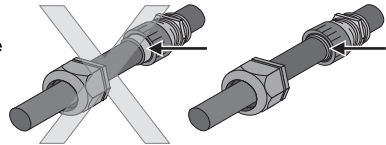

5. Screw the cable gland into the Sunny SensorBox with a torque of 7 in-lbs. (0.8 Nm).
 6. Remove the porous rubber seal in the Sunny SensorBox lid and replace it with the new one.
 7. Reinsert the relevant cable into the enclosure and make all the necessary connections.
 8. Make sure the cable opening seals of the cable gland are seated properly.
 9. Screw the lock nuts onto the cable gland with a torque of 7 in-lbs. (0.8 Nm).
 10. Close the Sunny SensorBox (see page 66).
- The gaskets of the cable gland have been replaced.

9.5 Care

Use a soft and moist cloth to clean the Sunny SensorBox and the RS485 Power Injector or SMA Power Injector with *Bluetooth*. Make sure the cloth is made of scratch-free material so as to avoid damaging the surface of the enclosure. If there is a considerable amount of dirt, you can also use a mild, non-abrasive and non-corrosive cleaning agent.

10 Decommissioning

10.1 Dismantling the Sunny SensorBox

1. Remove the plug-in power supply unit of the RS485 Power Injector or SMA Power Injector with *Bluetooth* from the power outlet or disconnect the alternate power source of the SMA Power Injector with *Bluetooth*.
 2. Remove all cable connections in the Sunny SensorBox:
 - **RS485 Power Injector:** Disconnect the Sunny SensorBox and RS485 Power Injector cables in the reverse order in which they are connected. Make sure the RS485 communication bus has been terminated.
 - **SMA Power Injector with *Bluetooth*:** Disconnect the Sunny SensorBox and SMA Power Injector with *Bluetooth* cables in the reverse order in which they were connected.
 3. Dismantle the Sunny SensorBox in the reverse order in which it is mounted.
- The Sunny SensorBox is now dismantled.

10.2 Dismantling the RS485 Power Injector



Hold the RS485 Power Injector firmly in place when connecting or disconnecting the power cable or plug connector.

If not held securely, the device may pop out and cause damage or even destroy the wall mounting bracket.



If you want to retrofit or upgrade an existing PV system, you first need to modify its configuration so that the baud rate of the Sunny SensorBox is set at 1,200 Bd. You can now install the SMA Power Injector with *Bluetooth* and the Sunny SensorBox.

1. Remove all the cable connections of the RS485 Power Injector.
2. Detach the RS485 Power Injector from the wall mounting bracket as shown below.

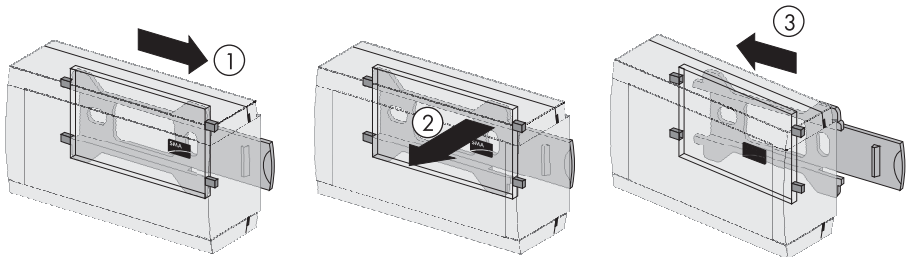

3. Unscrew the wall mounting bracket from the wall.
- The RS485 Power Injector is now dismantled.

10.3 Dismantling the SMA Power Injector with *Bluetooth*



Hold the RS485 Power Injector firmly in place when connecting or disconnecting the power cable or plug connector.

If not held securely, the device may pop out and cause damage or even destroy the wall mounting bracket.

1. Remove all the cable connections of the SMA Power Injector with *Bluetooth*.
2. Detach the SMA Power Injector with *Bluetooth* from the mounting bracket as illustrated below.

Removing the SMA Power Injector with *Bluetooth* from the wall

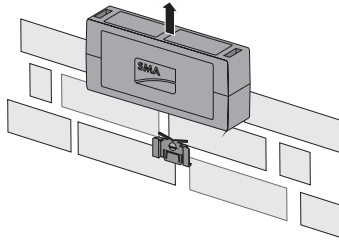

Removing the SMA Power Injector with *Bluetooth* from the top-hat rail

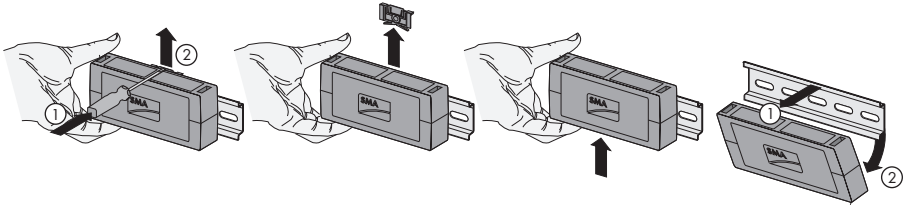

3. Unscrew the bracket from the wall.
- The SMA Power Injector with *Bluetooth* is dismantled.

10.4 Dismantling the sensors



If you want to dismantle the ambient temperature sensor, module temperature sensor or solar radiation sensor and remove all the connections in the Sunny SensorBox, the Sunny WebBox will display unrealistic data for these sensors.

- Disconnect the sensor cables in the reverse order in which they were connected.

10.5 Packaging the Sunny SensorBox and sensors

For reshipment, use a transport-secure packaging - if possible the original packaging.

10.6 Disposing of the Sunny SensorBox and sensors

At the end of their service life, Sunny SensorBoxes and their components can be disposed of in compliance with all current and local regulations regarding electronic waste disposal or, alternatively, sent back to SMA with shipping paid by the sender and labeled "FOR DISPOSAL".

11 Troubleshooting



If a particular error does not appear in this section, call the SMA Serviceline and have the information listed in section 16 "Contact" (page 88) on hand.

11.1 Sunny SensorBox

Problem	Cause	Rectification
The Sunny SensorBox cannot be found.	The RS485 bus is not terminated on the Sunny SensorBox.	Terminate the RS485 bus on the Sunny SensorBox. For information on RS485 cabling, refer to the RS485 cabling plan.
The LED of the Sunny SensorBox fails to light up within 60 seconds of being connected to the power supply.	The Sunny SensorBox does not have power.	Make sure the plug-in power supply unit of the RS485 Power Injector or SMA Power Injector with <i>Bluetooth</i> is connected to a power outlet. Check the connection between the RS485 Power Injector or SMA Power Injector with <i>Bluetooth</i> and the Sunny SensorBox.
The LED of the Sunny SensorBox flashes yellow every second.	Firmware error.	Contact the SMA Serviceline.
Sunny Explorer or Sunny WebBox with Bluetooth displays the wrong device.	More than one Sunny SensorBox is connected to the SMA Power Injector with <i>Bluetooth</i> .	Connect only one Sunny SensorBox to the SMA Power Injector with <i>Bluetooth</i> .
The "TmpAmb" display value shows one of the following values continuously: -273.15 °C, 0 K, -459.67 °F.	The ambient temperature sensor is not connected.	Connect the ambient temperature sensor to the Sunny SensorBox. Check the cabling.

Problem	Cause	Rectification
Unrealistic readings from the ambient temperature sensor are displayed.	The sensor is not connected properly.	Make sure the sensor is connected to the right terminal on the Sunny SensorBox.
	The sensor cable is damaged.	Inspect the cable for signs of damage and replace if necessary.
	The sensor is damaged or dirty.	Clean the sensor. Replace defective sensors.
	The sensor has been deactivated and the resistor is no longer connected to the Sunny SensorBox.	Plug the resistor into the connection terminal of the ambient temperature sensor.
	The requisite cable length was ignored.	Check the cable length. Adhere to the cable length specified in the sensor manual.
Unrealistic readings from the anemometer are displayed.	The sensor is not connected properly.	Make sure the sensor is connected to the right terminal on the Sunny SensorBox.
	The sensor cable is damaged.	Inspect the cable for signs of damage and replace if necessary.
	The sensor is damaged or dirty.	Clean the sensor. Replace defective sensors.
	The requisite cable length was ignored.	Check the cable length. Adhere to the cable length specified in the sensor manual.
Unrealistic readings from the integrated solar radiation sensor are displayed.	The sensor is not connected properly.	Make sure the sensor is connected to the right terminal on the Sunny SensorBox.
	The sensor cable is damaged.	Inspect the cable for signs of damage and replace if necessary.
	The sensor is damaged or dirty.	Clean the sensor. Replace defective sensors.

11.2 RS485 Power Injector

Problem	Cause	Rectification
The "Power" LED on the RS485 Power Injector does not light up.	The RS485 Power Injector does not have power.	Make sure the plug-in power supply unit of the RS485 Power Injector is connected to a power outlet.

11.3 SMA Power Injector with *Bluetooth*

Problem	Cause	Rectification
Only the "RDY" LED of the SMA Power Injector with <i>Bluetooth</i> is on.	The Sunny SensorBox is not connected.	Connect one Sunny SensorBox to the SMA Power Injector with <i>Bluetooth</i> .
The "RDY" LED of the SMA Power Injector with <i>Bluetooth</i> does not light up.	The SMA Power Injector with <i>Bluetooth</i> does not have power.	Make sure the plug-in power supply unit of the SMA Power Injector with <i>Bluetooth</i> is connected to a power outlet or the alternate power source is running. Replace the defective devices.
	The supply voltage is too low.	Check the alternate power source. Observe the requirements for the alternate power source (see page 65).
The "RDY" LED of the SMA Power Injector with <i>Bluetooth</i> flashes.	The supply voltage is borderline.	Improve the power supply of the alternate power source in one of the following ways: <ul style="list-style-type: none"> • Shorten the cable. • Use cables with a larger cross-section.
		Use the plug-in power supply unit that is provided as an accessory for the SMA Power Injector with <i>Bluetooth</i> (see 63).
The "COM" LED of the SMA Power Injector with <i>Bluetooth</i> fails to flash.	Incorrect cabling - the wires of the RS485 communication cable were either inverted during connection or not connected at all.	Check the cabling.

12 Parameters

12.1 RS485 Power Injector

The communication product helps you to display the parameter list on your computer. The list provides display values and configurable parameters. Display values such as the serial number (SN) are read only. Configurable parameters such as the unit of temperature (TmpUnit) can be changed.

12.1.1 Display values

Sunny SensorBox

Name	Description
SN	serial number of the Sunny SensorBox
FwVer	firmware version of the Sunny SensorBox
HwVer	hardware version of the Sunny SensorBox
OpTm	operating hours of the Sunny SensorBox since initial startup

Internal solar radiation sensor

Name	Description
IntSollrr	current level of solar radiation in W/m ²

Module temperature sensor *

Name	Description
TmpMdul C	module temperature in °C
TmpMdul K	module temperature in K
TmpMdul F	module temperature in °F

* If no module temperature sensor is connected, absolute zero is displayed (-273.15 °C, 0 K, -459.67 °F).

Ambient temperature sensor *

Name	Description
TmpAmb C	ambient temperature in °C
TmpAmb K	ambient temperature in K
TmpAmb F	ambient temperature in °F

* If no ambient temperature sensor is connected, absolute zero is displayed (-273.15 °C, 0 K, -459.67 °F).

Anemometer*

Name	Description
WindVel m/s	wind velocity in m/s
WindVel km/h	wind velocity in km/h
WindVel mph	wind velocity in mph

* If no anemometer is connected or the wind velocity exceeds the measurement range, "0" is displayed in these channels.

12.1.2 Configurable parameters

Name	Description	Value / range	Explanation	Default value
DevNam	device name	Text	allocation of a user-defined device name	
TmpUnit	unit of temperature	°C	degrees Celsius	°C
		K	Kelvin	
		°F	degrees Fahrenheit	
WindUnit	unit for wind velocity	m/s		m/s
		km/h		
		mph		
DevRs	Sunny SensorBox reset	0 ms ... 255 ms	for reset, enter "1" and save; the specified parameter will not be added and the LED in the Sunny SensorBox remains off for 60 seconds	0
RS485DI	response delay of the Sunny SensorBox to the RS485 bus; this parameter is only visible if you are logged in as an "installer" in the communication device	0 ms ... 1.000 ms	if you are using a Sunny Boy Control/Plus, this parameter must be set to "200 ms"; if you are using a Sunny WebBox, the response delay can be reduced to "10 ms".	200 ms

Name	Description	Value / range	Explanation	Default value
SmaNetBd	value for baud rate	300 baud	communication problems may occur if some devices are unable to achieve 1,200 baud, which is the standard SMA baud rate setting. Adjust the baud rate if necessary.	1,200 baud
		600 baud		
		1,200 baud		
		2,400 baud		
		4,800 baud		
		9,600 baud		
		19,200 baud		
		38,400 baud		
		57,600 baud		
		115,200 baud		
		230,400 baud		

12.2 SMA Power Injector with *Bluetooth*

The display values and parameter list are displayed on the web interface of the Sunny WebBox with *Bluetooth* and in Sunny Explorer. Display values are read only.

12.2.1 Display values *

Name	Description
Status	general values that describe the status of the device; the status of other components in the device (e.g., modems) are not listed here
System communication	all values that define communication between the communication devices and the PV system
Meteorology	includes all measured values of the connected sensors (e.g., temperature, radiation, wind velocity)

*The display values are determined by the respective country settings of the communication products.

12.2.2 Configurable parameters

Name	Description	Value / range	Explanation
DevNam	device name	Text	allocation of a user-defined device name

13 Technical Data

13.1 Sunny SensorBox

Mechanical data

Width x Height x Depth	4 ³ / ₄ in. x 2 in. x 3 ¹ / ₂ in. (120 mm x 50 mm x 90 mm)
Weight	500 g
Mounting method	mounting plate/roof bracket
Mounting location	outdoors

Power supply

Power supply via	RS485 Power Injector / SMA Power Injector with <i>Bluetooth</i>
Power consumption	< 1 W

Ambient conditions

Ambient temperature	- 13 °F ... + 158 °F (- 25 °C ... + 70 °C)
Protection rating*	IP65

* Protection rating according to DIN EN 60529

Communication

Communication	RS485 (RS485 Power Injector) / <i>Bluetooth</i> (SMA Power Injector with <i>Bluetooth</i>)
---------------	--

Integrated solar radiation sensor

PV cell type	PV cell, amorphous silicon (aSi)
Measurement range	0 W/m ² ... 1,500 W/m ²
Measurement accuracy	± 8 %
Resolution	1 W/m ²

Module temperature sensor

Measuring resistor	platinum sensor (PT100)
Protection rating*	IP62
Cable length**	8 ft. (2.5 m)
Measurement range	- 4 °F ... + 230 °F (- 20 °C ... + 110 °C)
Measurement accuracy	± 1 °F (± 0.5 °C)
Resolution	0.18 °F (0.1 °C)

* Protection rating according to DIN EN 60529

** Connection cable with two-wire technology

13.2 RS485 Power Injector

Mechanical data

Width x Height x Depth	4 ¹ / ₈ in. x 2 ³ / ₁₆ in. x 9 ³ / ₁₆ in. (105 mm x 55 mm x 30 mm)
Weight	80 g
Mounting method	wall mounting, tabletop device
Mounting location	indoors

Power supply

Power supply via	plug-in power supply
Power consumption*	< 5 W
Maximum number of Sunny SensorBoxes that can be operated	5

*With five Sunny SensorBox devices

Ambient conditions

Ambient temperature	- 4 °F ... + 149 °F (- 20 °C ... + 65 °C)
Relative air humidity	5 % ... 95 %, non condensing
Protection rating*	IP20

*Protection rating according to DIN EN 60529

Communication

Maximum communication range of RS485	3,900 ft. (1,200 m)
--------------------------------------	---------------------

Other

Maximum cable length to the last Sunny SensorBox in the RS485 bus	490 ft. (150 m)
---	-----------------

13.3 SMA Power Injector with *Bluetooth*

Mechanical data

Width x Height x Depth	5 ⁵ / ₈ in. x 1 ⁵ / ₈ in. x 3 in. (142 mm x 40 mm x 76 mm)
Weight	144 g
Way of mounting	wall mounting/top-hat rail mounting
Mounting location	indoors

Power supply

Power supply via	plug-in power supply/power module/alternate power source
Power module/alternate power source	2-pole socket
Typical power consumption	0.8 W
Maximum power consumption	1.5 W
Maximum number of Sunny SensorBoxes that can be operated	1
Input voltage of power module/alternate power source	typically 12 V ... 24 V AC ± 10 %, 50 Hz / 60 Hz or typically 12 V ... 24 V DC ± 20 %

Ambient conditions

Ambient temperature during operation	- 4 °F ... + 149 °F (- 20 °C ... + 65 °C)
Ambient temperature during storage and transport	- 13 °F ... + 158 °F (- 25 °C ... + 70 °C)
Relative air humidity	5 % ... 95 %, non-condensing
Protection rating*	IP20
Elevation above mean sea level (AMSL)	0 ft. ... 9,800 ft. (0 m ... 3,000 m)

* Protection rating according to DIN EN 60529

Communication

Maximum free field communication range of <i>Bluetooth</i> *	328 ft. (100 m)
--	-----------------

* Can be extended with SMA Bluetooth Repeater.

Other

Maximum cable length to the last Sunny SensorBox	490 ft. (150 m)
Maximum number of nodes in a <i>Bluetooth</i> network	50

13.4 Plug-in Power Supply

CINCON, TRG30R 120

Mechanical data

Width x height x depth	4 $\frac{1}{4}$ in. x 2 $\frac{5}{16}$ in. x 1 $\frac{11}{32}$ in. (108 mm x 58 mm x 34 mm)
Weight	10 $\frac{5}{8}$ oz. (300 g)

Power supply

Voltage	100 V ... 240 V AC, 50 / 60 Hz
Nominal current	0.8 A

TaiyTech, TYT251200200 UV/3000

Mechanical data

Width x height x depth	3 $\frac{5}{8}$ in. x 2 $\frac{5}{16}$ in. x 1 $\frac{13}{8}$ in. (92 mm x 58 mm x 41 mm)
Weight	8 $\frac{5}{8}$ oz. (244 g)

Power supply

Voltage	100 V ... 240 V AC, 50 / 60 Hz
Nominal current	0.75 A

TaiyTech, TYT251200200EU/3000

Mechanical data

Width x height x depth	3 $\frac{5}{8}$ in. x 3 $\frac{9}{16}$ in. x 1 $\frac{7}{16}$ in. (92 mm x 90 mm x 36 mm)
Weight	4 $\frac{9}{16}$ oz. (128 g)

Power supply

Voltage	100 V ... 240 V AC, 50 / 60 Hz
Nominal current	0.75 A

14 Accessories

14.1 Mounting plate

SMA order number: Monplat-Ssensor

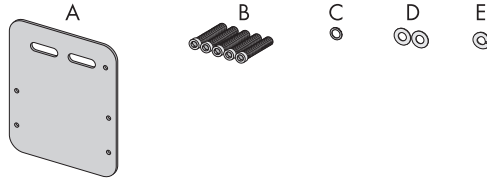

Position	Quantity	Designation
A	1	Mounting plate
B	5	M4 hexagonal screws *
C	1	M4 contact washer *
D	2	Washers *
E	1	Locking washer *

* Pre-mounted on delivery.

14.2 Roof bracket

SMA order number: Roofan-Ssensor

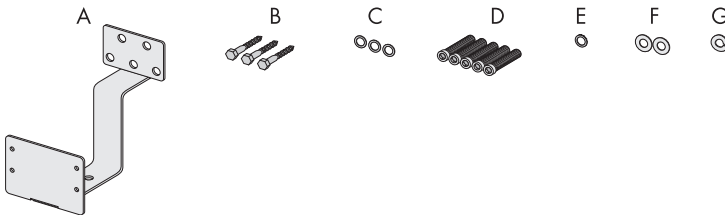

Position	Quantity	Designation
A	1	Roof bracket
B	3	Hexagonal wood screws
C	3	Washers for hexagonal wood screws
D	5	M4 hexagonal screws *
E	1	M4 contact washer *
F	2	Washers *

* Pre-mounted on delivery.

14.3 Gasket set for Sunny SensorBox

SMA order number: Sealkit-Ssensor

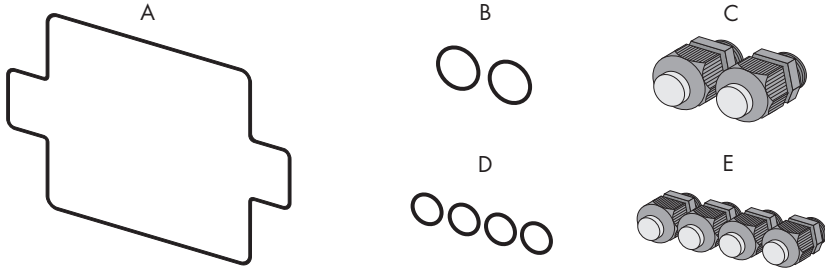

Position	Quantity	Designation
A	1	Enclosure seal
B	2	Gaskets of the cable glands for the RS485 communication bus
C	2	Cable glands for the RS485 communication bus
D	4	Gaskets of the cable glands for the sensors
E	4	Cable glands for the sensors

14.4 RS485 Power Injector

SMA order number: Power-Injector

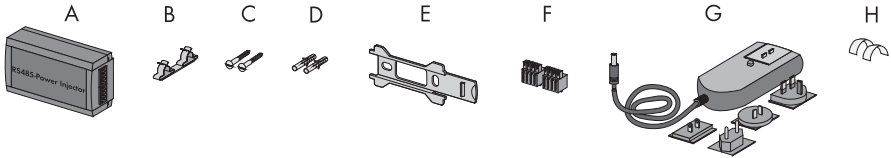

Position	Quantity	Designation
A	1	RS485 Power Injector
B	1	Shield clamp
C	2	Screws
D	2	Wall anchors
E	1	Wall mounting bracket
F	2	4-pole plugs
G	1	Plug-in power supply with plug adapter
H	2	Conductive adhesive films

14.5 SMA Power Injector with Bluetooth

SMA order number: BT-485-CON-DEV

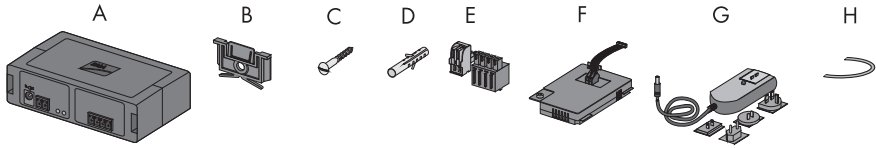

Position	Quantity	Designation
A	1	SMA Power Injector with <i>Bluetooth</i>
B	1	Bracket for wall or top-hat rail*
C	1	Screw
D	1	Wall anchor
E	1	Plug (1 x 2 poles, 1 x 4 poles)
F	1	Power module for supplying power (scope of delivery listed in power module installation guide) - only with order option SUNNYSSENSOR-3xxx
G	1	Plug-in power supply with plug adapter - only with order option SUNNYSSENSOR-2xxx
H	1	Ground cable

* Can be found on the back of the SMA Power Injector with *Bluetooth* on delivery.

14.6 Anemometer

SMA order number: WIND-SENSOR

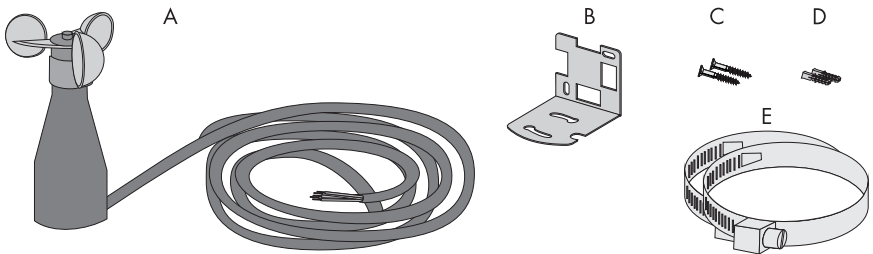

Position	Quantity	Designation
A	1	Anemometer with 3 m connection cable and screws on the bottom
B	1	Mounting bracket
C	2	Screws
D	2	Wall anchors
E	2	Straps

15 Compliance information

FCC Compliance

This device complies with Part 15 of the FCC Rules. Operation is subject to the following conditions:

1. this device may not cause harmful interference, and
2. this device must accept any interference received, including interference that may cause undesired operation.

NOTE: This equipment has been tested and found to comply with the limits for a Class B digital device, pursuant to Part 15 of the FCC Rules. These limits are designed to provide reasonable protection against harmful interference in a residential installation. This equipment generates, uses, and can radiate radio frequency energy and if not installed and used in accordance with the instructions, may cause harmful interference to radio communications. However, there is no guarantee that interference will not occur in a particular installation. If this equipment does cause harmful interference to radio or television reception, which can be determined by turning the equipment off and on, the user is encouraged to try to correct the interference by one or more of the following measures:

- Reorient or relocate the receiving antenna.
- Increase the separation between the equipment and the receiver.
- Connect the equipment into an outlet on a circuit different from that to which the receiver is connected.
- Consult the dealer or an experienced radio/TV technician for help.

The user is cautioned that changes or modifications not expressly approved by SMA America, LLC could void the user's authority to operate this equipment.

IC Compliance

This Class B digital apparatus complies with Canadian ICES-003.

The SMA Power Injector with *Bluetooth* complies with Industry Canada licence-exempt RSS standard(s). Operation is subject to the following two conditions:

1. this device may not cause interference, and
2. this device must accept any interference, including interference that may cause undesired operation of the device.

RF Exposure

This equipment should be installed and operated with minimum distance of 8 in. (20 cm) between the radiator and your body.

16 Contact

If you have technical problems concerning our products, contact the SMA Serviceline. We require the following information in order to provide you with the necessary assistance:

- Type of inverters and serial number
- Serial number and firmware version of the communication device
- Serial number and firmware version of the Sunny SensorBox

SMA Solar Technology America, LLC

6020 West Oaks Blvd, Ste 300

Rocklin, CA 95765

Tel. +1 916 625 0870

Tel. +1 877-MY SMA TECH

Tel. +1 877 697 6283 (Toll free, available for USA, Canada and Puerto Rico)

Fax +1 916 625 0871

Service@SMA-America.com

www.SMA-America.com

SMA Solar Technology Canada Inc.

2425 Matheson Blvd E

8th Floor

Mississauga, ON L4W 5K5

Canada

SMA America, LLC

www.SMA-America.com



Soligent

YOUR SU A DISTRIBUTOR
SOLIGENT
800-967-6917
www.soligent.net